

| Display in LCD | Meaning |
|--|---|
| Submenus | |
| INF | INF menu |
| n01 | Firmware version of LUB-S-B |
| h06 | Currently set value of dispensing time h |
| c01 | Currently set value of number of strokes c |
| 6 | Currently set value of emptying time Et |
| SET | SET menu |
| -h- | Operating mode: hour mode |
| Et | Operating mode: empty time mode |
| RUN | RUN menu |
| 01...35 | During the manually triggered active RUN command („quick check“/extra dispense), the LCD displays the approximate back pressure in bar. In addition, the green LED lights up. |
| PRO | PRO menu |
| h1...99 | Adjustable setting of dispensing time h |
| c1...10 | Adjustable setting of number of strokes c |
| 01...24 | Adjustable setting of emptying time Et |
| FIL | FIL menu |
| 01...35 | During the manually triggered active FIL command, the LCD displays the approximate back pressure in bar. In addition, the green LED lights up. |
| Clr | If the process is aborted during the FIL command, Clr appears at first. |
| Additional characters on the LCD | |
|  | Displayed when the cartridge is empty and the cartridge and battery need to be replaced. |
| MAX | After each cycle the maximum back pressure is displayed in bar. |

5.3 Actions with the activation and programming key

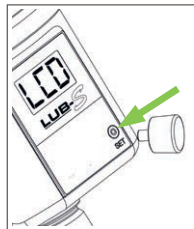

1. Remove the activation and programming key from the underside of LUB-S-B.
2. Place the activation and programming key on the action area on the front of LUB-S-B.
3. Remove the activation and programming key from the action area as long as the desired menu item is displayed in the LCD.

5.4 SET menu

The SET menu allows you to change the operating mode of LUB-S-B. You can switch between **hour mode -h-** and **empty time mode -Et-**.

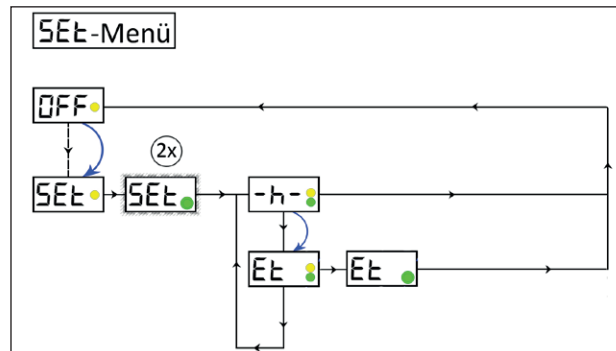

-h- Operating mode: hour mode -h-
Et Operating mode: empty time mode Et

If you would like to change the operating mode, move the activation and programming key back to the action area.

When your desired operating mode is displayed on the LCD, remove the activation and programming key from the action area.

5.5 PRO menu

Being in operating mode hour mode -h-, you can change the dispensing time h as well as the number of cycles c (number of strokes).

Being in PRO menu the first step is to set the dispensing time h and afterwards the number of cycles c; direct access to the number of cycles c is not possible.

Being in empty time mode Et, you can change the emptying time Et in months.

5.6 FIL menu

This function enables you to prefill connected accessories (tubes, distributors,...) with the lubricant contained in the lubricant cartridge, especially during the initial start-up of LUB-S-B. However, the process can also be aborted manually at any time.

6. Maintenance

NOTICE

A used lubricant cartridge must not be replaced on LUB-S-B as the integrated stroke counter of LUB-S-B is automatically reset by the cartridge sensor after a cartridge has been removed. Only use full lubricant cartridges.

NOTICE

The battery of LUB-S-B must be replaced at the same time as the lubricant cartridge.

LUB-S

Quick start guide LUB-S-B (Battery)



This brief instruction of mounting LUB-S-B addresses to experienced users. Please visit www.G-LUBE.com to download the complete user manual including all safety instructions.

1. Overview LUB-S-B

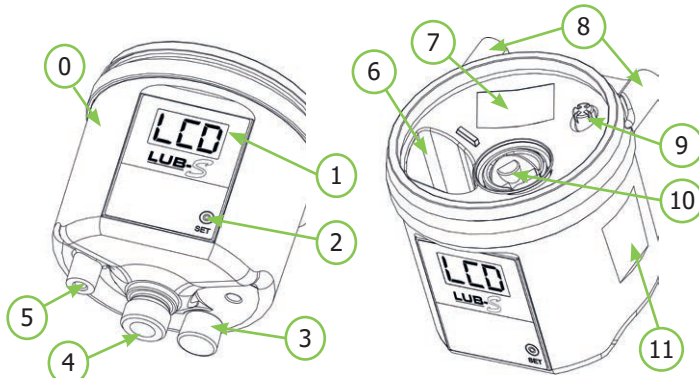

| No. | Description |
|-----|---|
| 0 | LUB-S-B |
| 1 | LCD |
| 2 | Operation pad (for actions with the activation and programming key) |
| 3 | Activation and programming key |
| 4 | Lubricant outlet |
| 5 | M5 female thread for bottom mounting |
| 6 | Battery compartment |
| 7 | Serial number of LUB-S-B |
| 8 | M5 female thread for rear mounting |
| 9 | Cartridge sensor |
| 10 | Lubricant inlet with thread for cartridge |
| 11 | Nameplate with designation and CE mark |

2. Technical data

| Housing | | | |
|-------------------------|--|-------------|-----------------|
| mounting options | backside: female thread M5 (2x) bottom: female thread M5 (1x) bottom: male thread M16x1.5 (1x) | | |
| max. torque mounting | 3 | | Nm |
| mounting position | any, upright (preferred) | | |
| operating temperature | Alcaline battery: | +15 ... +60 | °C |
| | Lithium battery: | -15 ... +60 | |
| Lubricant and hydraulic | | | |
| max. pressure | 35 (-10%/+15%) | | bar |
| grease delivery | per stroke | 0.16 (-5%) | cm ³ |
| Electrics | | | |
| operating voltage | 4.5 | | V |
| protection class | IP 54 | | |

3. Mounting

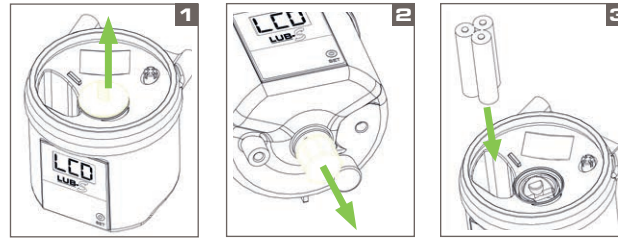

1. Remove the yellow protective cap from the top of the lubricant inlet of LUB-S-B.
2. Unscrew the yellow protective cap counterclockwise from the bottom of the lubricant outlet of LUB-S-B.
3. Connect the battery to the battery cable using the plug.
4. Turn the cap on the lubricant cartridge counterclockwise and pull it off.
5. Place the full lubricant cartridge on LUB-S-B. Turn the lubricant cartridge clockwise onto LUB-S-B.

4. Commissioning

1. Mechanical fastening

Fix LUB-S-B mechanically through the M5 female threads or through the M16x1.5 male thread of the lubricant outlet. Pay particular attention to the maximum tightening torques permissible for the M5 female threads!

2. Power on

3. Execute FIL function

4. Hydraulic connection

Connect the consumer hydraulically to LUB-S-B. If you connect tubes to LUB-S-B, make sure that tubes and connectors are installed tightly, cleanly and correctly.

The tube length shall not exceed 4 meters, the inner tube diameter shall not be lower than 4 mm.

① Ideally, use tubes prefilled with the appropriate lubricant.

5. Check settings on LUB-S-B

Check the required values for the lubrication point at the factory settings of LUB-S-B and adjust them if necessary.

Factory settings: operating mode=hour mode.

5. Operation and settings

Two operating modes can be selected.

The **hour mode -h-** allows setting the number of cycles (c) within a dispensing time (h) in hours. The cycles are evenly distributed over the dispensing time. Dispensing times between 1...99 hour(s) and cycles (c) between 1...10 can be set.

The **empty time mode Et** allows the emptying time of the cartridge to be set in months. Emptying times between 1...24 month(s) can be set.

5.1 Default settings operating mode hour mode -h-

Dispensing time h = 6

The dispensing time is 6 hours.

Number of cycles c = 1

The number of cycles is one (1) stroke during the dispensing time.

5.2 Menu and LCD messages

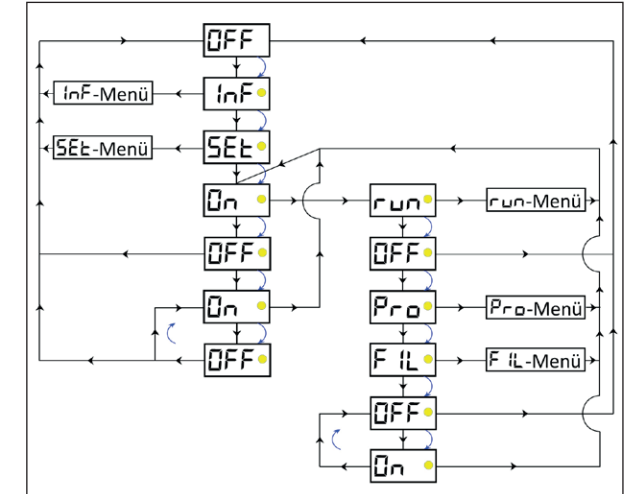

The graphic above illustrates the unchangeable basic flowchart of the LUB-S-B menu navigation as well as the options for branching to submenus.

① LUB-S-B can be switched on and off at several points in the menu navigation.

① The INF menu provides you with an informative overview of the current LUB-S-B settings.

① The SET menu allows you to make changes to the operating mode.

① The RUN menu allows you to manually trigger a single dispense at LUB-S-B.

① The PRO menu allows you to make changes to the LUB-S-B settings - and thus to its dispensing behavior.

① The FIL menu allows you to manually trigger a fixed number of dispenses at LUB-S-B.

| Display in LCD | Meaning |
|----------------|--|
| Errors | |
| E1 | Error E1 (cartridge empty / cartridge error) |
| E2 | Error E2 (overload / overpressure) |
| E3 | Error E3 (battery empty) |
| E4 | Error E4 (fatal error) |