

LUB-S

User manual LUB-S-V (24 VDC)



GRUETZNER
AUTOMATIC LUBRICATION

I. Revision history & imprint

I.I Revision history

The present user manual is the original user manual.

This user manual is only valid for

Product:

Product designation: Lubricus S-V (LUB-S-V)

Product revision: ---

User manual:

Date of creation: 10.2019

Revision of the user manual: 1

This document is protected by copyright.

All rights for layout, content, texts and corporate design are reserved by Gruetzner GmbH, © 2019.

All rights, including those of photomechanical reproduction, duplication and distribution by means of special processes (e.g. data processing, data carriers and data networks), even in part and/or in extracts, are reserved by Gruetzner GmbH.

The content and technical specifications are subject to change without notice.

I.II Imprint

Address:

Gruetzner GmbH

Dagobertstr. 15

90431 Nuremberg, Germany

Tel: +49 (0)911 277 399-0

Fax: +49 (0)911 277 399-99

info@G-LUBE.com

www.G-LUBE.com

Commercial Register of Nuremberg Local Court: HRB 12109

USt.-ID: DE 160441123

CEO: Volker Grütznér

I.II Table of contents

Chapter	Content	Page
I.	Revision history & imprint	02
I.I	Revision history	02
I.II	Imprint of the manufacturer, distribution and service	02
I.III	Table of contents	03
1.	General information about this manual	06
1.1	Signal words	06
1.2	Warning symbols	07
1.3	Structure of safety instructions	07
1.4	Symbols for information	07
2.	Safety	08
2.1	EC/EU Directive	08
2.2	Hazards	08
2.3	Staff	08
2.4	Reasonably predictable misuse	08
2.5	Usage for the intended purpose	09
2.6	Warranty and Liability	09
2.7	General safety instructions	10
3.	Description of function	11
3.1	General information	11
3.2	Nameplate and designation	12
3.3	Scope of delivery	12
3.4	Technical data	13
4.	Transport and storage	14
4.1	Packaging	14
4.2	Transport	14
4.3	Storage	14
5.	Mounting	15
5.1	Preparations	15
5.2	Assembly	15
5.3	Commissioning	18

Chapter	Content	Page
6.	Operation and settings	19
6.1	General information	19
6.2	Factory settings	21
6.2.1	Default settings, operating mode: hour mode -h-	21
6.2.2	Default settings, operating mode: empty time mode Et	22
6.2.3	Default settings, operating mode: impulse mode PUL	22
6.3	Menu and LCD messages	23
6.3.1	LCD	26
6.3.2	Actions with the activation and programming key	29
6.3.3	Switching on and off	31
6.3.4	INF menu, operating mode: hour mode -h-	32
6.3.5	INF menu, operating mode: empty time mode Et	33
6.3.6	INF menu, operating mode: impulse mode PUL	34
6.3.7	SET menu	35
6.3.8	RUN menu	37
6.3.9	PRO menu, operating mode: hour mode -h-	39
6.3.10	PRO menu, operating mode: empty time mode Et	42
6.3.11	PRO menu, operating mode: impulse mode PUL	44
6.3.12	FIL menu	45
6.4	Error messages	46
7.	Input and output signals - time control	48
7.1	Terminal pin assignment	48
7.2	Output signals and LCD messages	48
7.3	Output signals at PIN 4	49
8.	Input and output signals - external control (PLC)	50
8.1	Terminal pin assignment	50
8.2	Input signals	51
8.2.1	Control signal 2 seconds	52
8.2.2	Control signal 12 seconds	54
8.2.3	Control signal 14 seconds	56
8.3	Output signals and LCD messages	58
8.3.1	Error E1 (cartridge empty)	59
8.3.2	Error E1 (cartridge error)	61
8.3.3	Error E2 (overload)	62
8.3.4	Error E3 (undervoltage)	63
8.3.5	Error E4 (fatal error)	64

Chapter	Content	Page
9.	Maintenance and disposal	65
9.1	Maintenance schedule	65
9.1.1	Visual check	66
9.1.2	Cleaning	66
9.1.3	Recommissioning after maintenance	66
9.2	Cartridge change	67
9.3	Disposal	69
10.	Released accessories	70
10.1	Lubricants	71
10.2	Tube lengths	71
11.	Appendix	72
11.1	Dimension sheet and installation dimensions	72
11.2	EC/EU declaration of conformity	73
11.3	Spare parts	74
11.4	Flow chart impulse mode PUL	75

1. General information about this manual

This user manual contains all necessary information to use Lubricus S-V (24 VDC version), hereinafter referred to as LUB-S-V, safely and as intended. In the event that supplementary sheets are attached to these instructions, the information and data contained there are valid and replace the corresponding information in this user manual. Any contradictory information contained in this user manual thus becomes invalid. If you have any questions regarding special applications, please contact Gruetzner GmbH (chapter I.II).

The actual and factual operator must ensure and guarantee that these instructions, including any supplementary sheets, have been read and understood by all persons responsible for the installation, operation or maintenance of LUB-S-V. Therefore, keep these instructions in a suitable place, ideally in an easily accessible place in the surrounding area of LUB-S-V.

Inform your colleagues who work in the local area of the machine about safety instructions so nobody gets hurt.

This manual was written in German, all other language versions are translations of this manual.

1.1 Signal words

The following signal words are used in this manual to draw your attention to possible dangers, prohibitions and other important information:

DANGER

This signal word points you to an immediate and threatening risk of serious injury or death.

WARNING

This signal word indicates a potentially imminent danger which can result in serious injury or even death.

CAUTION

This signal word indicates a potentially imminent danger that can result in minor to severe injuries.

NOTICE



This signal word indicates a potentially imminent danger which can result in damage to property.

INFORMATION

This signal word refers to practical application tips or particularly important information when using LUB-S-V.

1.2 Warning symbols

The following warning symbols are used in this user manual to alert you to hazards, prohibitions and important information:

		
General warning sign	Electricity hazard	Flammable material



1.3 Structure of the safety instructions

The safety instructions in this user manual are structured according to the following system:

	CAUTION
	<p>This text explains the consequences of disregarding the reference.</p> <ul style="list-style-type: none"> • This text shows what to do as an instruction.

1.4 Symbols for information

The following information symbols are used in the text and instructions in this manual:

-  Requests you to take action
-  Shows the consequences of an action
-  Additional information about the action

2. Safety

All persons working with LUB-S-V must follow these operating instructions, in particular the safety instructions and the rules and regulations applicable at the place of use. Generally applicable legal regulations and other rules as well as the relevant rules and regulations for accident prevention (e.g. personal protective equipment (PPE)) and environmental protection must be observed.

2.1 EC/EU Directive

Within the scope of the EC/EU Directive, (re)commissioning of a machine on which LUB-S-V has been installed and/or fitted is prohibited until it has been clearly established that the machine complies with the provisions of the applicable directive. An EC/EU declaration of conformity for LUB-S-V can be found in the appendix (chapter 11.2).

2.2 Hazards

In order to avoid danger to the user or damage to the machine on which LUB-S-V is used, LUB-S-V may only be used for its intended purpose (chapter 2.5) and in a technically safe condition.

Always inform yourself about the general safety instructions (chapter 2.7) before starting to work.

2.3 Staff

Only qualified staff who has read and understood this manual may work with LUB-S-V. Local and/or company regulations apply accordingly.

2.4 Reasonably predictable misuse

Any use of LUB-S-V which exceeds the maximum permissible technical data is generally considered to be improper and therefore prohibited.

2.5 Usage for the intended purpose

The following points must be observed for the intended purpose of using LUB-S-V:

- LUB-S-V is exclusively approved for industrial use.
- LUB-S-V may be used in accordance with the technical data (chapter 3.4) exclusively.
- Unauthorized structural alterations to LUB-S-V are not permitted.
- Read the user manual and act accordingly.
- During operation of LUB-S-V, a visual inspection of LUB-S-V as well as of the lubrication point must be carried out regularly. Any anomalies must be eliminated immediately and the cause must be rectified.
- Refilling the cartridge is not permitted.
- LUB-S-V may not be opened or disassembled.
- Only lubricants approved by the manufacturer may be used.
- Relevant regulations and rules on work safety, accident prevention and environmental protection must be observed.
- Work and activities with and on LUB-S-V are only permitted with appropriate authorization (chapter 2.3).

All other uses than the aforementioned intended usage or the disregard of one of the above points shall be deemed improper usage. In this case no liability and/or warranty is assumed.





2.6 Warranty and Liability

If the following items are disregarded, all warranty and liability claims for personal injury and/or damage to property are excluded:

- non-observance of the instructions on transport and storage;
- misuse;
- improper or unperformed maintenance or repair work;
- improper assembly / disassembly or improper operation;
- operation of LUB-S-V with defective protective devices;
- operation of LUB-S-V without lubricant;
- operation of LUB-S-V with non-approved lubricant;
- operation of heavily contaminated LUB-S-V;
- modifications or alterations which may be carried out without the written permission of Gruetzner GmbH have taken place;
- opening and/or partial or complete disassembly of LUB-S-V.

2.7 General safety instructions

The following safety instructions are given for LUB-S-V:

	<p style="text-align: center;">DANGER</p> <p>Damaged or flawed electrical connections or unlicensed hot components lead to heavy injuries or even death.</p> <ul style="list-style-type: none"> • All work on electrical connections shall be provided by qualified personnel only. • Immediately change damaged cables or plugs.
	<p style="text-align: center;">NOTICE</p> <p>Loose or overloaded screw connections can cause damage to LUB-S-V.</p> <ul style="list-style-type: none"> • Mount and check all screw connections with the permissible torques specified for this purpose. Use a calibrated torque wrench.
	<p style="text-align: center;">WARNING</p> <p>Lubricants are flammable.</p> <ul style="list-style-type: none"> • In case of fire do not use a water jet to extinguish. • In case of fire only use suitable extinguishing agents such as powder, foam and carbon dioxide. • Observe the relevant safety instructions of the lubricant manufacturer on the safety data sheet of the lubricant used.
	<p style="text-align: center;">CAUTION</p> <p>Lubricants can cause skin irritations.</p> <ul style="list-style-type: none"> • Avoid direct skin contact.
	<p style="text-align: center;">NOTICE</p> <p>Lubricants can contaminate soil and water.</p> <ul style="list-style-type: none"> • Use and dispose lubricants properly.

3. Description of function

3.1 General information

LUB-S-V is designed as an extremely compact double piston pump for autonomous operation with lubricants. The two pistons run force-controlled and counterrotating. They are united into one outlet. The outlet is secured by an integrated non-return valve. Approx. 0.16 cm³ of lubricant is pumped during each dispensing operation; multiple dispensers can be set one after the other.

The LCD on the front panel displays the various operating states; further information (empty cartridge, error) can be read.

The present Lubricus S-V as 24 VDC version has an electrical interface. The supplied activation and programming key can be used to adjust the operating mode and the quantity of lubricant pumped per time to supply the lubrication point with the ideal quantity of lubricant.

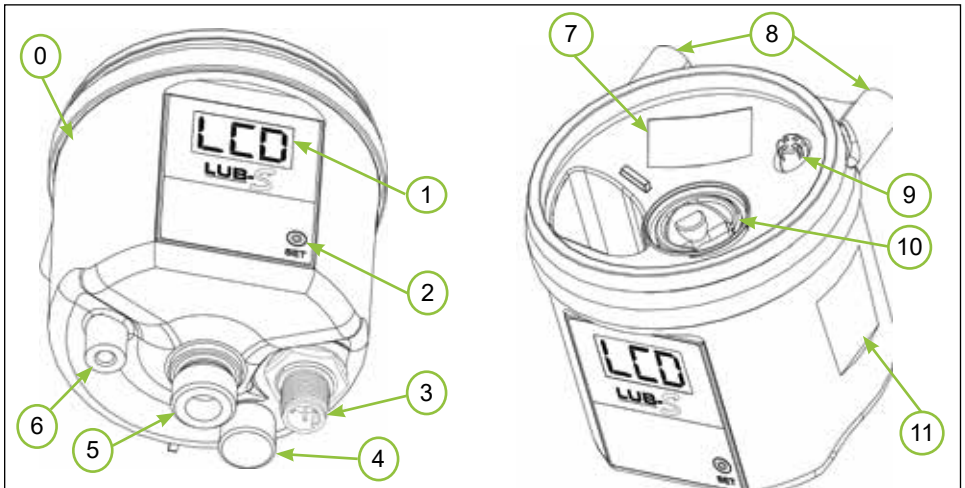

Fig. 1: Overview LUB-S-V

No.	Description
0	LUB-S-V
1	LCD
2	Operation pad (for actions with the activation and programming key)
3	Electric interface M12x1
4	Activation and programming key
5	Lubricant outlet / M16 male thread for bottom mounting
6	M5 female thread for bottom mounting
7	Serial number of LUB-S-V
8	M5 female thread for rear mounting
9	Cartridge sensor
10	Lubricant inlet with thread for cartridge
11	Nameplate with designation and CE mark

3.2 Nameplate and designation

The nameplate of LUB-S-V is visibly attached to the side of the pump itself. There the CE mark and the serial number of LUB-S-V are visible. Refer to chapter 3, Fig. 1 for the location of the nameplate and serial number.

3.3 Scope of delivery

LUB-S-V is available in several different versions. They differ in the number of accessories supplied.

All versions of LUB-S-V are prefilled with a neutral, food-grade (H1) lubricant (approx. 3 cm³), which can be mixed with the lubricants approved by Gruetzner GmbH, to simplify the initial commissioning. The manufacturer's designation is Total Ceran FG. Further data and documentation on the lubricant Total Ceran FG are available on request from Gruetzner GmbH.

3.4 Technical data

Housing			
dimensions without cartridge	width x height x depth	83 x 82 x 85	mm
dimensions with cartridge 125 ml		83 x 152 x 85	
dimensions with cartridge 250 ml		83 x 175 x 85	
weight (without cartridge)	appx.	350	g
mounting options	backside: female thread M5 (2x) bottom: female thread M5 (1x) bottom: male thread M16x1.5 (1x)		
max. torque mounting		3	Nm
mounting position	any, upright (preferred)		
material housing	PA 6.6 GF30 / POM		
material outlet	stainless steel		
operating temperature		-15 ... +60	°C
Lubricant and hydraulic			
cartridge volume		125 or 250	cm ³
lubricant characteristics	oils and greases up to NLGI 2		
number of outlets	1		
hydraulic connection	directly or via PA tube		
number of lubrication points	up to 4 by using splitters* up to 10 by using progressive distributors*		
max. pressure		50 (-10%/+15%)	bar
grease delivery	per stroke	0.16 (-5%)	cm ³
Electrics			
display	LCD		
operating voltage		24 (+/- 5%)	V
protection		0,75 (slow blow)	A
protection class	IP 54		
current draw		$I_{max} < 0.3$ $I_{rest} < 0.025$	A
Please see chapters 7 and 8 for more information about electrics.			

* The stated value is down to the individual application and may extensively differ in some cases (depending on the lubricant and further conditions).

4. Transport and storage

4.1 Packaging

LUB-S-V is delivered in an outer packaging (cardboard box) and - depending on the scope of delivery - with a lubricant cartridge and other accessories in the same package. To protect them from moisture and dirt they are also packed in PE films.

To prevent the escape of the prefilled lubricant from LUB-S-V, appropriate protective caps are fitted into the lubricant supply and the lubricant outlet. Dispose the packaging materials at designated disposal points in compliance with the relevant national and company regulations.

After receiving LUB-S-V check the delivery note for completeness and correctness. Any missing parts or damages must be reported immediately to the forwarding agent, the insurance company or Gruetzner GmbH in writing.

4.2 Transport

NOTICE	
	<p>Hard shocks due to e.g. falling or setting down too hard can damage LUB-S-V.</p> <ul style="list-style-type: none"> • Do not throw LUB-S-V. • When using lifting equipment only use hoists and load handling attachments in perfect condition and with sufficient load capacity. • The permissible lifting weight of the lifting device must not be exceeded.

4.3 Storage

Store LUB-S-V in its original packaging in a vertical position in a dry, frost-free environment at an ambient temperature of +5 °C to +30 °C. The maximum storage time in unopened condition is 2 years.

The so-called "first-in-first-out" principle (fifo) is recommended for storage logistics.

5. Mounting

5.1 Preparations

Before starting to work, inform yourself in detail about LUB-S-V using this user manual; and follow the general safety instructions (section 2.7) in particular. Prepare the installation site carefully.

	NOTICE
	<p>Pressurised air can damage the seals of LUB-S-V and can transport dirt and foreign matter into LUB-S-V or the lubricant.</p> <ul style="list-style-type: none"> • Do not use pressurised air. • Make sure that there is no coarse dirt in the mounting area.

5.2 Assembly

1	<p>Condition as delivered</p> <p>LUB-S-V is delivered in a cardboard box. Depending on the version ordered further accessories such as battery, lubricant cartridge or additional tube connection parts are included. It also contains a short manual for experienced users to start up and assemble the unit for the first time.</p>
---	--

2	<div style="display: flex; align-items: center;">  <div style="margin-left: 20px;"> <p>Remove protective cap from top of LUB-S-V</p> <ul style="list-style-type: none"> ✦ Remove the yellow protective cap from the top of the lubricant inlet of LUB-S-V. ⓘ Make sure that no dirt, water or foreign bodies enter the lubricant inlet. </div> </div>
---	---

3



Remove protective cap from bottom of LUB-S-V

- ✦ Unscrew the yellow protective cap counterclockwise from the lubricant outlet on the bottom of LUB-S-V.
- ✦ Remove the black protective cap from the electrical interface on the bottom of LUB-S-V.

4



Connect electrical interface

- ✦ To connect LUB-S-V with an external power supply system add a proper connecting cable to the electrical interface on the bottom of LUB-S-V.
- ⓘ Depending on the application connecting cables with both straight or angled sockets can be used.
- ⓘ For more details on connecting cables please see chapters 7.1 and 8.1.

DANGER



Damaged or flawed electrical connections or unlicensed hot components lead to heavy injuries or even death.

- All work on electrical connections shall be provided by qualified personnel only.
- Immediately change damaged cables or plugs.
- Before working on electrical installations, always follow the five safety regulations of electrical engineering:
 - Isolate
 - Protect against accidental restart
 - Ensure all parts are deenergized
 - Ground and short-out
 - Cover nearby hot components

5

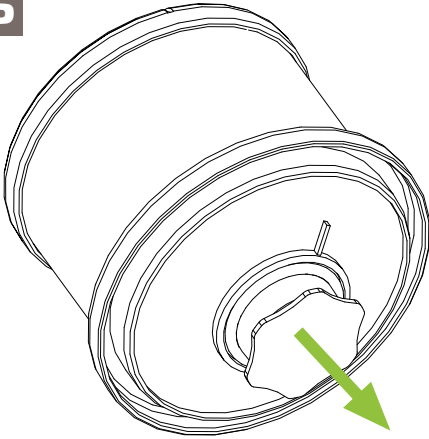

Unscrew cartridge cap

✦ Turn the cap on the lubricant cartridge counterclockwise and pull it off.

ⓘ Pay attention to cleanliness when working. It is imperative that dirt and foreign bodies do not enter the cartridge.

6



Mount lubricant cartridge

✦ Place the full lubricant cartridge on LUB-S-V.

✦ Turn the lubricant cartridge clockwise onto LUB-S-V.

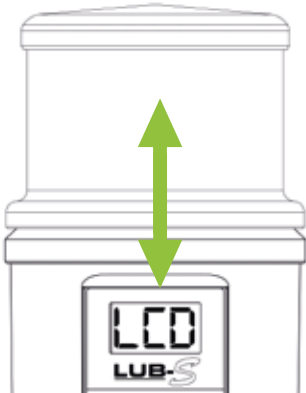

ⓘ The end position is reached after two full rotations when the label of the lubricant cartridge is aligned with the front label of LUB-S-V.

5.3 Commissioning

Mount LUB-S-V carefully according to the steps described in chapter 5.2. Depending on the scope of delivery, you must also carry out the following additional measures for first-time commissioning:

1. Mechanical fastening

Fix LUB-S-V mechanically through the M5 female threads or through the M16x1.5 male thread of the lubricant outlet. Pay particular attention to the maximum tightening torques permissible for the M5 female threads!

2. Electrical connection

Connect LUB-S-V and an external power supply system (e.g. PLC) by adding a proper connecting cable to the electrical interface on the bottom of LUB-S-V.

2. Check the assembly

Make sure that LUB-S-V is assembled properly and completely. In particular, the external power supply system has to be connected and a lubricant cartridge must have been fitted.

3. Power on

If you want to put LUB-S-V into operation, switch on LUB-S-V. LUB-S-V only delivers lubricant to the lubrication point according to the settings when switched on. The detailed description for powering on can be found in chapter 6.3.3.

4. Execute FIL function

Execute the FIL function. The detailed description can be found in chapter 6.3.12. LUB-S-V performs a certain number of strokes and transports lubricant from the cartridge to the outlet.

5. Hydraulic connection

Connect the consumer hydraulically to LUB-S-V. If you connect tubes to LUB-S-V make sure that tubes and connectors are installed tightly, cleanly and correctly.

 Ideally, use tubes prefilled with the appropriate lubricant.

6. Check the settings on LUB-S-V

Check the required values for the lubrication point at the factory settings of LUB-S-V and adjust them if necessary. The factory settings are recorded in chapter 6.2; changes at LUB-S-V can be made in the SET menu, chapter. 6.3.7, and in the PRO menu, chapter 6.3.9 to 6.3.11.

6. Operation and settings

6.1 General information

What you should know about operating and setting LUB-S-V:

✓ LUB-S-V is designed as a single point lubricator for one lubrication point. Accessories from the manufacturer can be connected to LUB-S-V (e.g. splitters or progressive distributors). If necessary, changes must be made to the settings to ensure a safe and reliable operation.

✓ LUB-S-V is a cycle-controlled lubricant dispenser which operates autonomously and time-based via the integrated microelectronics. It is connected to an external power supply system (24 V). LUB-S-V cyclically delivers a defined quantity of lubricant from the cartridge to the outlet. Three operating modes can be selected.

The hour mode -h- allows setting the number of cycles (c) within a pause time (h) in hours. The cycles (c) are evenly distributed over the pause time. Pause times (h) between 1...240 hour(s) and cycles (c) between 1...10 can be set.

The **empty time mode Et** allows the emptying time of the cartridge to be set in months. Emptying times between 1...24 month(s) can be set.

Additionally, LUB-S-V can be embedded into a programmable logic controller (PLC) which sends orders and controls LUB-S-V in **impulse mode** (see chapters 6 and 8).

✓ The dispensing cycle consists of 1...10 single dispenses (strokes) which are executed back-to-back. LUB-S-V will initiate the next dispensing cycle automatically as soon as the pause time runs out.

✓ The disposable, interchangeable cartridge containing 125 or 250 ml lubricant guarantees a controlled and constant quality of the lubricant and is filled bubble-free. LUB-S-V allows a high supply security of the lubrication point and prevents failures.

✓ LUB-S-V can only be operated with a lubricant cartridge and a connected external power supply system (24 VDC). The cartridge - depending on the version ordered - can already be included in the scope of delivery and may already be connected and installed in LUB-S-V.

- ✓ The respective conditions of LUB-S-V can be seen in the LCD. It additionally enables the optical recognition of the condition by means of coloured LEDs.
- ✓ If you have any questions about your application and the correct settings for LUB-S-V, please contact the manufacturer (chapter I.II).

6.2 Factory settings

LUB-S-V is always delivered with the following factory settings:

operating mode:	hour mode -h-	
mode:	OFF	LUB-S-V is switched off

ⓘ The factory settings provide the use of LUB-S-V in hour mode -h-. If you would like to operate LUB-S-V in empty time mode Et or impulse mode PUL you have to make changes in the SET menu of LUB-S-V (chapter 6.3.7).

6.2.1 Default settings, operating mode: hour mode -h-

Pause time	h = 6	The pause time is 6 hours.
Number of cycles	c = 1	The number of cycles is one (1) stroke during pause time.

ⓘ The default settings in hour mode result in an emptying time (service life) of 195 days (= 6.4 months) for a full 125 ml lubricant cartridge, provided that the LUB-S-V is permanently switched on and no special dispenses have been made. Within approx. 6 hours, LUB-S-V will deliver one dispense per stroke (0.16 cm³).

✦ Verify that the default settings are appropriate for your application and that the lubrication point is supplied with the correct amount of lubricant per time unit. If this is the case, you can operate LUB-S-V with the default settings in hour mode -h-.

If this is **not** the case change the values for the pause time h and number of cycles c accordingly; see chapter 6.3.9 for an explanation of how to make these changes.

ⓘ To use LUB-S-V it must be properly mounted and installed first and then switched on. The installation is very simple and is described in detail in chapter 5.2; switching on is described in chapter 6.3.3.

ⓘ If you order a factory-provided special version of LUB-S-V, the information contained in the supplement is authoritative.

7.2.2 Default settings, operating mode: empty time mode Et

Emptying time $E_t = 6$ The emptying time of one (1) cartridge is 6 months.

ⓘ The default settings in empty time mode result in an emptying time (service life) of 6 months for a full 125 or 250 ml lubricant cartridge, provided that LUB-S-V is permanently switched on and no special dispenses have been made.

When using a 125 ml cartridge LUB-S-V will deliver one dispense per stroke (0.16 cm^3) within approx. 5.6 hours.

When using a 250 ml cartridge LUB-S-V will deliver one dispense per stroke (0.16 cm^3) within approx. 2.8 hours.

✦ Verify that the default settings are appropriate for your application and that the lubrication point is supplied with the correct amount of lubricant per time unit. If this is the case, you can operate LUB-S-V with the default settings in empty time mode Et.

If this is **not** the case change the values for the emptying time t accordingly; see chapter 6.3.10 for an explanation of how to make these changes.

ⓘ To use LUB-S-V, it must first be properly mounted and installed and then switched on. The installation is very simple and is described in detail in chapter 5.2; switching on is described in chapter 6.3.3.

ⓘ If you order a factory-provided special version of LUB-S-V, the information contained in the supplement is authoritative.

7.2.3 Default settings, operating mode: impulse mode PUL

Impulse mode PUL enables embedding LUB-S-V in an external control (PLC) to command and control the device. The number of strokes (one stroke= 0.16 cm^3) dispensed now depend on the PLC's signals.

✦ Ensure that your PLC program is appropriate for your application and that the lubrication point is supplied with the correct amount of lubricant per time unit.

If this is the case you can operate LUB-S-V in impulse mode PUL.

If this is **not** the case change settings of your PLC.

ⓘ To use LUB-S-V it must first be properly mounted and installed and then switched on. The installation is very simple and is described in detail in chapter 5.2; switching on is described in chapter 6.3.3.

ⓘ If you order a factory-provided special version of LUB-S-V the information contained in the supplement is authoritative.



6.3 Menu and LCD messages

The LCD of LUB-S-V can be used to read information, to change settings with the activation and programming key on the underside of LUB-S-V or to trigger individual actions.

Generally, settings can be changed and actions can be triggered when LUB-S-V is switched off (OFF) and when it is switched on (ON).

The individual submenus are presented, described and explained in detail in chapters 6.3.4 to 6.3.12.

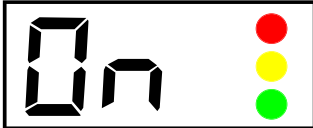
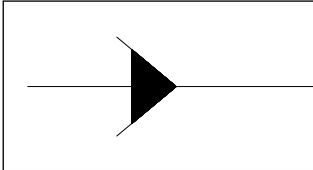
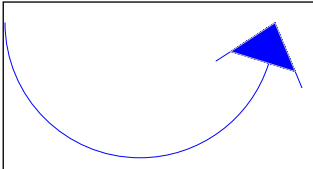
The symbolic representations used below are described as follows:

Symbol	Description	Note	Chapter
	LCD display	The LCD displays information both during operation and for programming purposes.	6.3.1
	Sequence arrow	The black sequence arrow indicates the unchangeable basic structure of the menu.	./.
	Action arrow	The blue action arrow shows the consequence of touching the action area with the activation and programming key.	6.3.2
	Submenu	In the respective submenu's information can be read, dispensing processes can be initiated and settings can be changed.	6.3.4 to 6.3.12



- ① The PRO menu is only accessible from ON mode (LUB-S-V is switched on). The PRO menu allows you to make changes to the LUB-S-V settings - and thus to its dispensing behavior. For details see chapters 6.3.9 to 6.3.11.
- ① The FIL menu is only accessible from ON mode (LUB-S-V is switched on). The FIL menu allows you to manually trigger a fixed number of dispenses at LUB-S-V. For details see chapter 6.3.12.

6.3.1 LCD

The LCD displays information about various states of LUB-S-V.

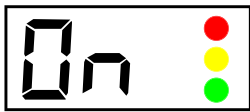
Depending on the state of the LUB-S-V you will be supported by three coloured LEDs to the right of the LCD. This allows you to assess the condition of LUB-S-V from a distance. Basic meanings: green=OK; red=error. The following tables show the LED assignment on the LCD as well as the explanation of the respective output.

LCD	Assignment
	upper LED: red middle LED: yellow lower LED: green

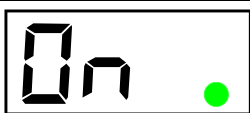
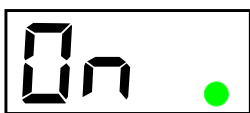
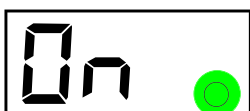
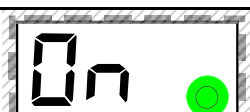
LCD	Description	Naming	Chapter
	The red LED only lights up if there is an error.	Error on LUB-S-V	6.4
	The yellow LED only lights up if the activation and programming key has touched the action surface (activation and programming key detected).	Activation and programming key detected by LUB-S-V	6.3
	The green LED lights up during a dispensing process for approx. 10...18 seconds.	LUB-S-V dispenses lubricant	6.3
	The green LED lights up when changes are possible and the activation and programming key was previously detected.	Changes possible	6.3
	The green LED flashes every 5 seconds when LUB-S-V is ON and no error occurs.	LUB-S-V is ready for use	6.3
	The green LED flashes twice when a value has been confirmed. Additionally the LCD also flashes twice.	Acceptance of changed value	6.3

Display in LCD		Meaning	Chapter
no display		Power supply not connected	6.3.3
OFF		LUB-S-V is switched off	6.3.3
On		LUB-S-V is ready for operation; LUB-S-V dispenses lubricant in accordance to the operating mode and the values set	6.3.3
PUL		LUB-S-V is ready for operation in impulse mode PUL and waits for control signals from the PLC	8
PUL (flashing)		LUB-S-V is receiving a control signal from the PLC	8
---		Received control signal longer than 15 seconds	8.2
Errors			
E1		Error E1 (empty cartridge / cartridge error)	6.4
E2		Error E2 (overload / overpressure)	6.4
E3		Error E3 (undervoltage)	6.4
E4		Error E4 (fatal error)	6.4
Submenus			
INF	INF menu		6.3.4
	b01	Firmware version of LUB-S-V	6.3.5
	h06	Currently set value of pause time h	6.3.6
	c01	Currently set value of number of strokes c	
	6	Currently set value of emptying time Et	
	PUL	Currently set operating mode: impulse mode	
	125	Currently set value of cartridge size	
SET	SET menu		6.3.7
	-h-	Operating mode: hour mode	
	Et	Operating mode: empty time mode	
	PUL	Operating mode: impulse mode	
	125/250	Changeable value of cartridge size	
RUN	RUN menu		6.3.8
	01...35	During the manually triggered active RUN command ("quick check"/extra dispense), the LCD displays the approximate back pressure in bar. In addition, the green LED lights up.	

PRO	PRO menu		6.3.9
	h1...99	Adjustable setting of pause time h	6.3.10
	c1...10	Adjustable setting of number of strokes c	6.3.11
	1...24	Adjustable setting of emptying time Et	
	PUL	Currently set operating mode: impulse mode No changeable value	
FIL	FIL menu		6.3.12
	01...50	During the manually triggered, active FIL command, the LCD displays the approximate back pressure in bar. In addition, the green LED lights up.	
	Clr	If the process is aborted during FIL command Clr appears at first.	
Additional character on the LCD			
		Displayed when the cartridge is empty and needs to be replaced.	9.2
MAX		After each cycle the maximum back pressure is displayed in bar.	

6.3.2 Actions with the activation and programming key

The activation and programming key attached to the bottom of LUB-S-V allows you to perform actions and changes in the settings of LUB-S-V. This activation and programming key can be easily and permanently stored underneath LUB-S-V.

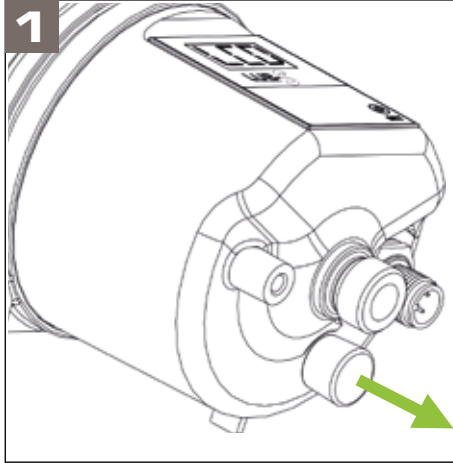

1 Remove the key

✦ Remove the activation and programming key from the underside of LUB-S-V.

ⓘ The activation and programming key is permanently held magnetically in the hole on the underside. Simply pull it out.

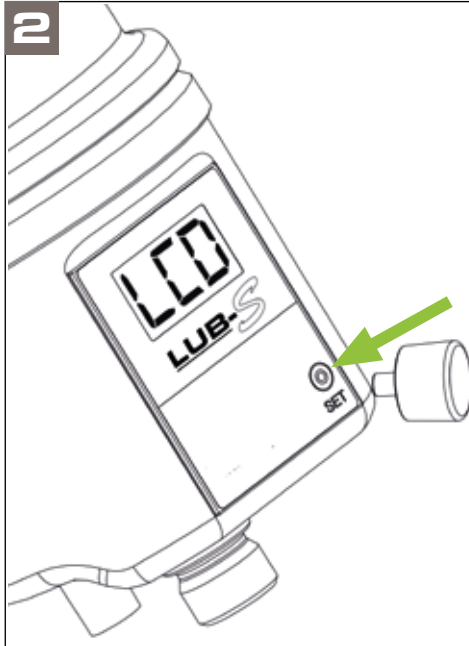

2 Guide the activation and programming key to the action area (SET)

✦ Place the activation and programming key on the action area on the front of LUB-S-V.

➡ As soon as the activation and programming key on the action area (SET) has been detected by LUB-S-V, the yellow LED lights up. The menu blends in in a rhythm of approx. 2 seconds.

✦ Remove the activation and programming key from the action area (SET) as long as the desired menu item is displayed in the LCD.

➡ The yellow LED disappears. You have performed an action. The LCD and the green LED flash twice.

✦ At the end of the action or setting reinsert the activation and programming key into the hole provided on the underside of LUB-S-V again.

ⓘ The hole on the bottom of LUB-S-V does not necessarily have to be used to store the activation and programming key. If you want to protect LUB-S-V against unintentional modification or manipulation, you can also store the activation and programming key in another location. Please note, however, that if faults or changes shall be made, no changes or actions can be carried out on LUB-S-V without the activation and programming key.

6.3.3 Switching on and off

Switching on LUB-S-V:

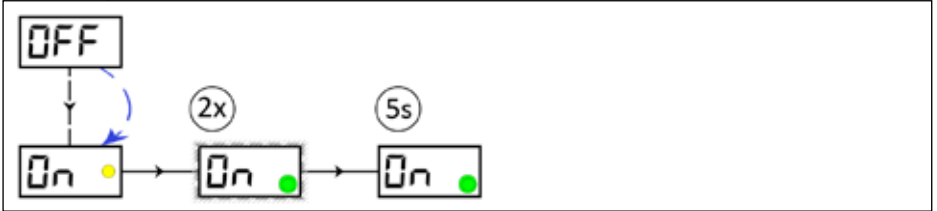

✓ LUB-S-V is switched off (OFF).

✦ Hold the activation and programming key onto the action surface. The yellow LED lights up. Leave the key on the action area until ON is displayed in the LCD. Remove the activation and programming key from the action area as long as ON is displayed. The yellow LED disappears; the LCD and the green LED flash twice.

⇒ If no error is detected during the LUB-S-V self-check, ON is displayed in the LCD. The green LED lights up once every 5 seconds, LUB-S-V is ready for operation and will dispense lubricant according to the set values.

✦ Insert the activation and programming key into the hole provided on the underside of LUB-S-V.

Switching off LUB-S-V:



✓ LUB-S-V is switched on (ON), the green LED flashes every 5 seconds.

✦ Hold the activation and programming key onto the action surface. The yellow LED lights up. Leave the activation and programming key on the action area until OFF is displayed in the LCD. Remove the activation and programming key from the action area as long as OFF is displayed. The yellow LED disappears; the LCD and the green LED flash twice.

⇒ LUB-S-V is OFF; OFF appears in the LCD. LUB-S-V stops dispensing lubricant.

✦ Insert the activation and programming key into the hole provided on the underside of LUB-S-V.

ⓘ LUB-S-V can be switched off in any state (normal operating state or error) in the manner described above.

6.3.4 INF menu, operating mode: hour mode -h-

The INF menu informs the user about the firmware used in LUB-S-V and the settings made earlier and are currently active (values of the adjustable variables t and c that can be changed in the PRO menu).

In the INF menu nothing can be changed by the user. The values of the parameters are displayed in a fixed order.

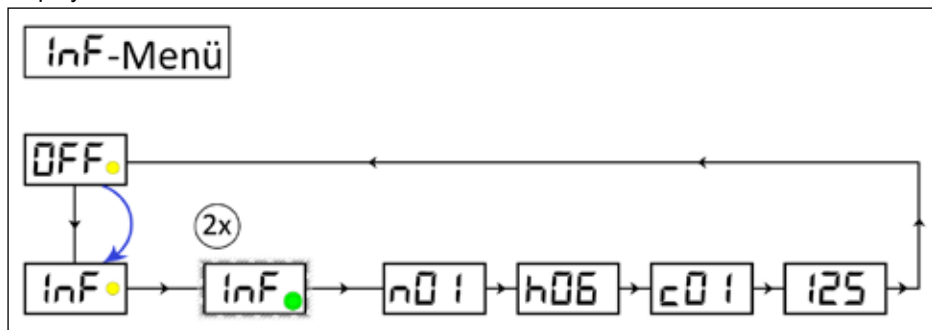

n alphanumeric name of the LUB-S-V firmware

h set value of variable *h* pause time

c set value of variable *c* number of cycles

125 set value of the size of the lubricant cartridge

✦ Remove the activation and programming key from the bottom of LUB-S-V and place it onto the action area.

✦ Hold the activation and programming key onto the action surface. The yellow LED lights up. Leave the activation and programming key on the action area until INF is displayed in the LCD. Remove the activation and programming key from the action area as long as INF is displayed. The yellow LED disappears; the LCD and the green LED flash twice.

⇒ The LCD informs you on the set values.

✦ Insert the activation and programming key into the hole provided on the underside of LUB-S-V.

ⓘ The INF menu can only be accessed from OFF mode (LUB-S-V is switched off). When you have entered the INF menu, you will return to OFF mode.

6.3.5 INF menu, operating mode: empty time mode Et

The INF menu is used to inform the user about the firmware used in LUB-S-V and the settings made earlier and are currently active (value of the adjustable variable Et that can be changed in the PRO menu).

In the INF menu nothing can be changed by the user. The values of the parameters are displayed in a fixed order.

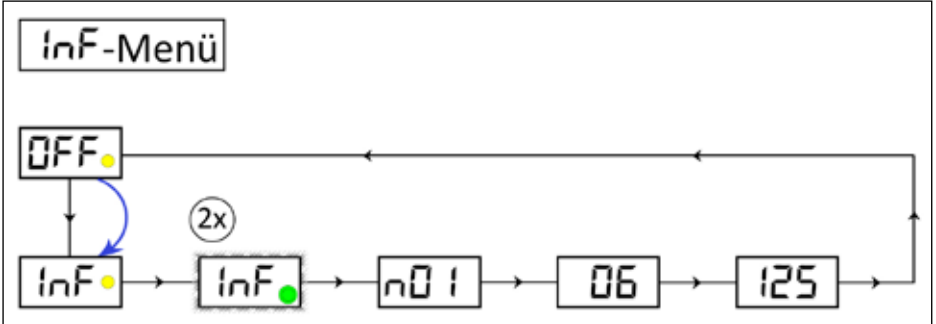

n alphanumerical name of the LUB-S-V firmware

Et set value of the variable Et emptying time in months

125 set value of the size of the lubricant cartridge

✦ Remove the activation and programming key from the bottom of LUB-S-V and place it onto the action area.

✦ Hold the activation and programming key on the action surface. The yellow LED lights up. Leave the activation and programming key on the action area until INF is displayed in the LCD. Remove the activation and programming key from the action area as long as INF is displayed. The yellow LED disappears; the LCD and the green LED flash twice.

➡ The LCD informs you on the set values.

✦ Insert the activation and programming key into the hole provided on the underside of LUB-S-V.

ⓘ The INF menu can only be accessed from OFF mode (LUB-S-V is switched off). When you have entered the INF menu, you will return to OFF mode.

6.3.6 INF-Menü im Betriebsmodus Impulsmodus PUL

The INF menu is used to inform the user about the firmware used in LUB-S-V and the settings made earlier and are currently active.

In the INF menu nothing can be changed by the user. The values of the parameters are displayed in a fixed order.

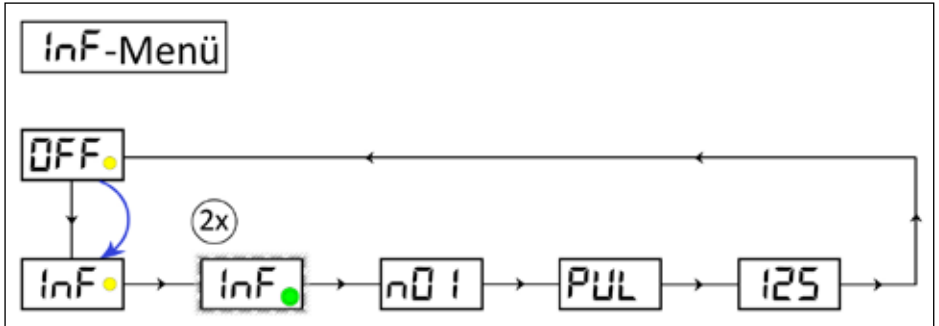

n alphanumerical name of the LUB-S-V firmware

PUL set operating mode: impulse mode (PUL)

125 set value of the size of the lubricant cartridge

✦ Remove the activation and programming key from the bottom of LUB-S-V and place it onto the action area.

✦ Hold the activation and programming key on the action surface. The yellow LED lights up. Leave the activation and programming key on the action area until INF is displayed in the LCD. Remove the activation and programming key from the action area as long as INF is displayed. The yellow LED disappears; the LCD and the green LED flash twice.

➡ The LCD informs you on the set values.

✦ Insert the activation and programming key into the hole provided on the underside of LUB-S-V.

ⓘ The INF menu can only be accessed from OFF mode (LUB-S-V is switched off). When you have entered the INF menu, you will return to OFF mode.

6.3.7 SET-Menü

The SET menu allows you to change the operating mode and the cartridge size of LUB-S-V. You can switch between hour mode -h-, empty time mode Et and impulse mode PUL. The hour mode -h- allows you to set the number of cycles (c) within a dispensing time (h) in hours. The empty time mode Et allows you to set the emptying time (Et) of the cartridge in months. The impulse mode allows you use a PLC to control LUB-S-V when embedded.

Cycles (c) and dispensing time (h) or emptying time (Et) can be adjusted after selecting the operating mode in the PRO menu, see chapters 6.3.9 to 6.3.11. The cartridge size of either 125 or 250 ml can be chosen.

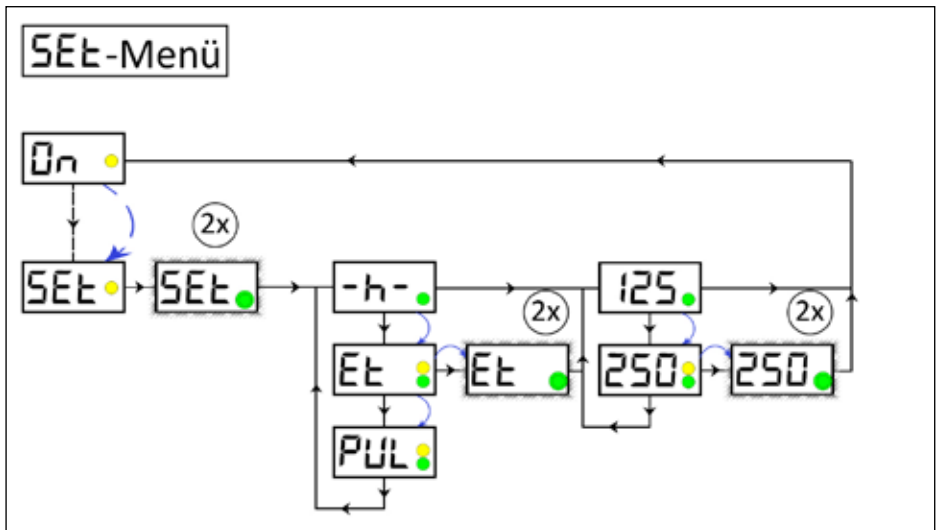

- h- Operating mode: hour mode -h-
- Et Operating mode: empty time mode Et
- PUL Operating mode: impulse mode PUL
- 125/250 Changeable value of cartridge size

✓ LUB-S-V is switched off (OFF)

✦ Remove the activation and programming key from the bottom of LUB-S-V and place it onto the action area.

✦ Hold the activation and programming key onto the action surface. The yellow LED lights up. Leave the activation and programming key on the action area until SET is displayed in the LCD.

- ✦ Remove the activation and programming key from the action area.
- ➡ The yellow LED disappears; the LCD and the green LED flash twice. The LCD displays the operating mode currently set. Now you are able to change the operating mode.

Changing the operating mode:

- ✦ If you would like to change the operating mode, move the activation and programming key back to the action area.
- ➡ The yellow LED lights up and the LCD displays the currently unselected operating mode. The yellow LED lights up as long as the activation and programming key is on the action surface; the two adjustable operating modes run alternately.
- ✦ When your desired operating mode is displayed on the LCD, remove the activation and programming key from the action area.
- ➡ The yellow LED disappears; the LCD and the green LED flash twice. The selected operating mode has now been accepted.

Not changing the operating mode:

- ✦ If you do not want to change operating mode, the activation and programming key must remain removed from the action area.
- ➡ The LCD and the green LED flash twice whereby the operating mode is displayed in the LCD.

The submenu automatically continues by showing the set cartridge size. You now may change its value.

Changing the value of the cartridge size:

- If you want to change the value of the cartridge size, move the activation and programming key back to the action area.
- ➡ The yellow LED lights up and the display shows the upcoming operating mode. The yellow LED lights up as long as the activation and programming key is on the action surface while all selectable operating modes are displayed one after another.
 - ✦ When your desired operating mode is displayed on the LCD, remove the activation and programming key from the action area.

Not changing the value of the cartridge size:

- ✦ If you do not want to change the value of the cartridge size, the activation and programming key must remain removed from the action area.
- ➡ The LCD and the green LED flash twice whereby the cartridge size is displayed in the LCD.

ⓘ The SET menu can only be accessed from OFF mode (LUB-S-V is switched off). When you have entered the SET menu, you will return to OFF mode.

6.3.8 RUN menu

The RUN menu is used to manually activate LUB-S-V and enables triggering an extra dispense. This function can be used, for example, to manually check the condition of the lubrication point ("quick check").

LUB-S-V carries out (an) extra dispense(s) after triggering the RUN function. Depending on the operating mode LUB-S-V either dispenses one stroke or as many as specified in PRO menu (value of changeable variable c). During the stroke, the back pressure detected by the integrated microelectronics is displayed in the LCD as an approximate value in bar.

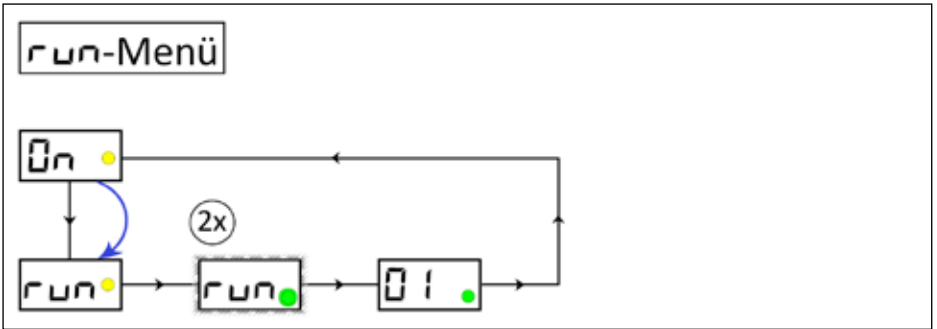

✓ There is no fault or error at LUB-S-V.

✦ Remove the activation and programming key from the bottom of LUB-S-V and place it onto the action area.

✦ Hold the activation and programming key onto the action surface. The yellow LED lights up. Leave the activation and programming key on the action area until RUN is displayed in the LCD. Remove the activation and programming key from the action area as long as RUN is displayed. The yellow LED disappears.

⇒ The LCD and the green LED flash twice. LUB-S-V starts to pump the lubricant to the outlet (extra dispense or "Quick check") depending on the value c set in PRO menu. (E.g. if c=1 is set, the RUN function triggers one stroke. If c=4 is set, 4 strokes are dispensed.)

✦ Insert the activation and programming key into the hole provided on the underside of LUB-S-V or repeat the extra dispense ("Quick check") if necessary.

✦ Observe the back pressure values displayed on the LCD if they are of interest.

① During the dispensing process the green LED lights up; in addition, the stroke's

counterpressure is displayed in the LCD.

- ① In hour mode -h- LUB-S-V dispenses as many strokes as set in PRO menu (value of changeable variable c).
- ① In empty-time mode -Et- LUB-S-V dispenses one stroke.
- ① The RUN menu can only be reached from ON mode (LUB-S-V switched on). When you have entered the RUN menu, you will return to ON mode.

6.3.9 PRO menu, operating mode: hour mode -h-

The PRO menu allows you to change the settings of LUB-S-V's dispensing behavior. Being in operating mode hour mode -h-, you can change the pause time h as well as the number of cycles c (number of strokes). After pause time h has expired LUB-S-V executes exactly the number of strokes c (each 0.16 cm^3) specified in the number of cycles c .

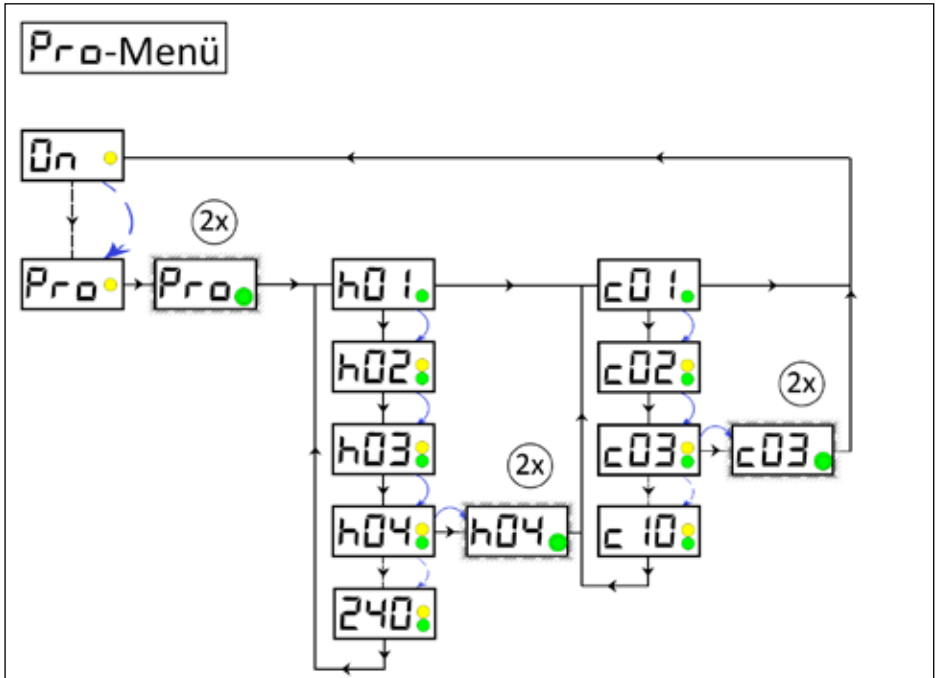

✓ There is no fault or error at LUB-S-V.

Being in PRO menu the first step is to set the pause time h and afterwards the number of cycles c ; direct access to the number of cycles c is not possible.

✦ Remove the activation and programming key from the bottom of LUB-S-V and place it onto the action area. Hold the activation and programming key onto the action surface. Leave the activation and programming key on the action area until PRO is displayed in the LCD.

✦ Remove the activation and programming key from the action area as long as PRO is displayed.

⊙ The LCD and the green LED flash twice. The LCD first displays the value of pause time h (h_s) currently set. Now you are able to change the values of pause time h .

Changing the value of pause time h:

✦ If you would like to change the value of pause time h, move the activation and programming key back to the action area.

➡ In the LCD the next higher ($h_{is} + 1$) adjustable value of pause time h is displayed. The green LED lights up as long as the activation and programming key is placed on the action surface; the other values of pause time h run through one after the other. However, you can also remove the activation and programming key from the action area and bring it back there shortly afterwards to reach each value one after the other. If the final value of the pause time h of $h=240$ is reached and no value has been selected, the menu returns to $h=01$ and the cycle can be restarted.

✦ As long as the new chosen value for pause time h (h_{new}) is displayed in the LCD, remove the activation and programming key from the action area.

➡ The yellow LED disappears, the green LED and the LCD flash twice. The selected new value ($h_{new} = h_{is}$) of pause time h has now been accepted. The submenu will now automatically take you to the values of the number of cycles c.

No changing of the value of pause time h:

✦ If you do not want to change the value of pause time h, the activation and programming key must remain removed from the action area immediately after entering the PRO menu.

➡ The LCD as well as the green LED flash twice and the pause time h is displayed in the LCD. The submenu now automatically takes you to the values of the number of cycles.

The LCD now displays the currently set value of the number of cycles c (c_{is}). Now you have the possibility to change the values of the number of cycles c.

Changing the value of the number of cycles c:

✦ If you want to change the value of the number of cycles c, move the activation and programming key back to the action area.

➡ In the LCD the next higher ($c_{is} + 1$) adjustable value of the number of cycles c is displayed. The green LED lights up as long as the activation and programming key is placed on the action surface; the other values of the number of cycles c run through one after the other. However, you can also remove the activation and programming key from the action area and bring it back there shortly afterwards to reach each value one after the other. If the final value of the number of cycles c of $c=10$ is reached and no value has been selected, the menu returns to $c=01$ and the cycle can be restarted.

✦ As long as the new chosen value for the number of cycles c (c_{new}) is displayed in the LCD, remove the activation and programming key from the action area.

➡ The yellow LED disappears, the green LED and the LCD flash twice. The selected new value ($c_{new} = c_{is}$) of pause time h has now been accepted.

No changing of the value of the number of cycles c:

✦ If you do not want to change the value of the number of cycles c the activation and programming key must remain removed from the action area immediately after entering the PRO menu.

➡ The LCD and the green LED flash twice and the number of cycles c is displayed in the LCD.

✦ Insert the activation and programming key into the hole provided on the underside of LUB-S-V.

ⓘ The PRO menu can only be reached from ON mode (LUB-S-V switched on). When leaving the PRO menu you will return to ON mode.

ⓘ If you have made changes to the values of pause time h or number of cycles c in PRO menu and LUB-S-V is otherwise ready for operation (battery full and inserted as well as a cartridge fitted), LUB-S-V will immediately trigger the newly set dispense and start the newly set waiting time until the next dispenses.

✦ Insert the activation and programming key into the hole provided on the underside of LUB-S-V.

✦ Observe the back pressure values displayed on the LCD if they are of interest.

ⓘ During the dispensing process the green LED lights up; in addition, the stroke's counterpressure is displayed in the LCD.

The parameters that can be set for pause time h and the number of cycles c and their respective permissible values are specified as follows:

h= **Pause time** in hours (h).

The pause time can be set between 1 | 2 | 3 | ... | 99 hours.

The time counter integrated in the microelectronics of LUB-S-V starts counting the pause time h at the end of a successful and fully completed dispensing cycle.

c= **Number of cycles** within a dispensing cycle (c).

The number of cycles c can be set between 1 | 2 | 3 | ... | 10 strokes.

6.3.10 PRO menu, operating mode: empty time mode Et

The PRO menu allows you to change the settings of the LUB-S-V's dispensing behavior. Running empty time mode Et, you can change the emptying time Et in months. LUB-S-V automatically calculates the pause time between two cycles to reach the set emptying time in months.

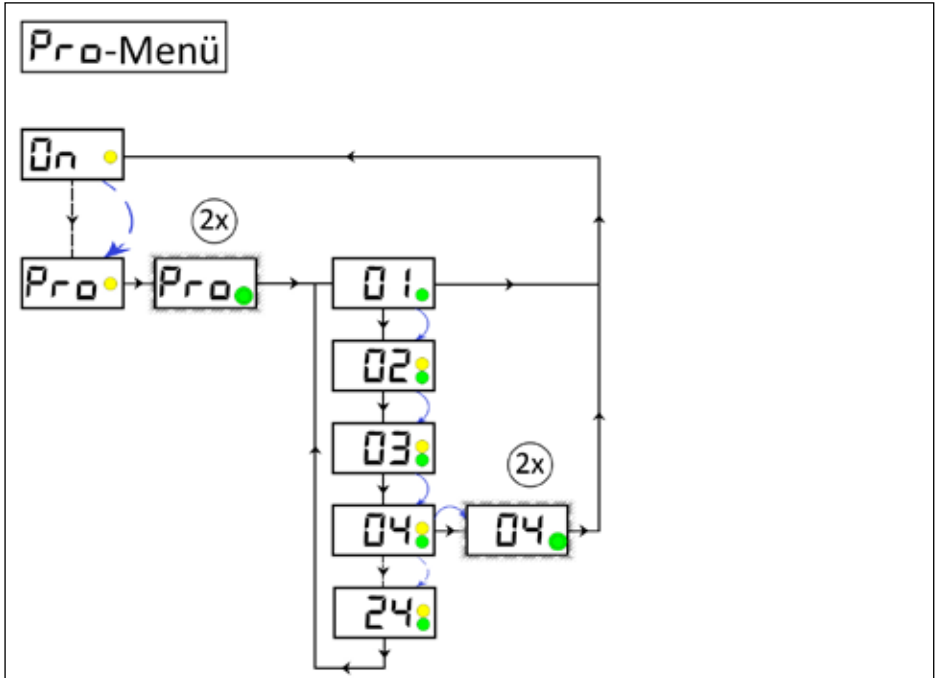

✓ There is no fault or error at LUB-S-V.

✦ Remove the activation and programming key from the bottom of LUB-S-V and place it onto the action area. Hold the activation and programming key onto the action surface. Leave the activation and programming key on the action area until PRO is displayed in the LCD.

✦ Remove the activation and programming key from the action area as long as PRO is displayed.

➡ The LCD and the green LED flash twice. The LCD first displays the value of the emptying time Et (Et_{is}) currently set. You are now able to change the values of emptying time Et.

Changing the value of emptying time Et:

✦ If you would like to change the value of emptying time Et, move the activation and programming key back to the action area.

➤ In the LCD the next higher ($Et_{is} + 1$) adjustable value of emptying time Et is displayed. The green LED lights up as long as the activation and programming key is placed onto the action surface; the other values of emptying time Et run through one after the other. However, you can also remove the activation and programming key from the action area and bring it back there shortly afterwards to reach each value one after the other. If the final value of emptying time Et of $Et=24$ is reached and no value has been selected the menu returns to $Et=01$ and the cycle can be restarted.

✦ As long as the new chosen value for emptying time Et (Et_{new}) is displayed in the LCD remove the activation and programming key from the action area.

➤ The yellow LED disappears, the green LED and the LCD flash twice. The selected new value ($Et_{new} = Et_{is}$) of pause time h has now been accepted.

No changing of the value of emptying time Et :

✦ If you do not want to change the value of emptying time Et the activation and programming key must remain removed from the action area immediately after entering the PRO menu.

➤ The LCD and the green LED flash twice and emptying time Et is displayed in the LCD.

✦ Insert the activation and programming key into the hole provided on the underside of LUB-S-V.

ⓘ The PRO menu can only be reached from ON mode (LUB-S-V switched on). When entering the PRO menu, you will return to ON mode.

ⓘ If you have made changes to the values of emptying time Et in PRO menu and LUB-S-V is otherwise ready for operation (battery full and inserted as well as a cartridge fitted), LUB-S-V will immediately start the calculated waiting time until the next dispenses.

✦ Observe the back pressure values displayed on the LCD if they are of interest.

ⓘ During the dispensing process the green LED lights up; in addition, the stroke's counterpressure is displayed in the LCD.

The parameters that can be set for emptying time Et and their respective permissible values are specified as follows:

Et = **Emptying time** of a full cartridge in months (Et).

The emptying time can be set between 1 | 2 | 3 | ... | 24 months.

The time counter integrated in the microelectronics of LUB-S-V starts counting the pause time at the end of a successful and fully completed dispensing cycle.

6.3.11 PRO menu, operating mode: impulse mode PUL

The PRO menu allows you to change the settings of the LUB-S-V's dispensing behavior. Running impulse mode PUL, settings can not be changed. An external control (PLC) in which LUB-S-V is embedded commands and controls the device, see chapters 6 and 8. The display shows PUL (impulse mode) for your information.

6.3.12 FIL menu

The FIL menu allows you to trigger a defined multiple dispense of LUB-S-V. The activation initiates a total of 40 pump strokes. This function enables you to prefill connected accessories (tubes, distributors,...) with the lubricant contained in the lubricant cartridge, especially during the initial start-up of LUB-S-V. However, the process can also be aborted manually at any time.

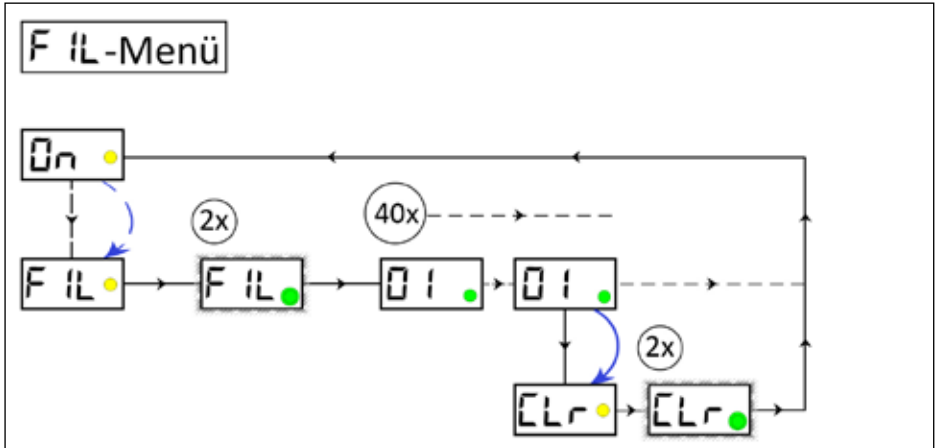

✓ There is no fault or error at LUB-S-V.

✦ Remove the activation and programming key from the bottom of LUB-S-V and place it on the action area. The yellow LED will light up. Leave the activation and programming key on the action area until FIL is displayed in the LCD. Remove the activation and programming key from the action area. The yellow LED disappears.

⇒ The LCD and the green LED flash twice. LUB-S-V starts dispensing. The green LED lights up during each dispense.

✦ If you do not want to cancel the process: Insert the activation and programming key into the hole provided on the underside of LUB-S-V.

⇒ LUB-S-V dispenses 40 strokes of lubricant.

✦ If you would like to cancel the process: Place the activation and programming key on the action area and wait until the end of a dispensing process (motor run).

⇒ CLR appears in the LCD.

✦ Remove the activation and programming key from the action area.



⇒ LUB-S-V stops the FIL command.

✦ Observe the back pressure values displayed on the LCD if they are of interest.

- ① During the dispensing process the green LED lights up; in addition, the stroke's counterpressure is displayed in the LCD.
- ① The FIL menu can only be reached from ON mode (LUB-S-V switched on). When you enter the FIL menu you will return to ON mode, even if you cancel FIL prematurely with CLR.

6.4 Error codes

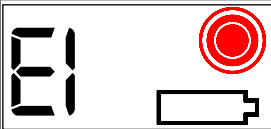
The microelectronics integrated in LUB-S-V permanently monitor the status. In case of irregularities an addressed error message is displayed on the LCD. The red LED flashes every 5 seconds and signals an error.

LCD	Name	Description	Remedy
	Error E1	Cartridge error; Cartridge not recognized or not mounted correctly	<ul style="list-style-type: none"> ✦ Place a new cartridge on LUB-S-V (see chapter 9.2). ① No confirmation of error necessary; it is automatically cleared after the remedial action.
	Error E1	Cartridge (symbol) empty	<ul style="list-style-type: none"> ✦ Place a new cartridge on LUB-S-V (see chapter 9.2). ① No confirmation of the error necessary; it is automatically cleared after the remedial action.
	Error E2	Overload, the backpressure at the lubrication point is too high	<ul style="list-style-type: none"> ✦ Check the lubrication point and eliminate the fault's cause. ✦ Switch LUB-S-V off (OFF) and on (ON) again.
	Error E3	Undervoltage	<ul style="list-style-type: none"> ✦ Switch LUB-S-V off (OFF). ✦ Check the power supply of LUB-S-V. ✦ Switch LUB-S-V on (ON).

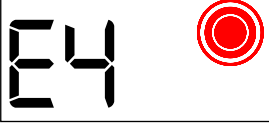
LCD	Name	Description	Remedy
	Error E4	Fatal error	<p>✦ Disassemble LUB-S-V and return it to the manufacturer together with the lubricant cartridge and a description of faults.</p> <p>ⓘ A fatal error usually concerns the electronics of LUB-S-V and cannot be repaired by you on site.</p> <p>ⓘ The manufacturer's address can be found in chapter I.II.</p>

ⓘ Running hour mode -h- or empty time mode -Et-, the errors E1...E4 are displayed as low level (0 V) via PIN 4 at the electrical interface (chapter 7.3).

ⓘ Running impulse mode PUL where LUB-S-V is controlled by an external control (PLC), detailed information about the errors E1...E4 are displayed via PIN 4 at the electrical interface (chapter 8.3).

7. Input and output signals - time control

LUB-S-V operates in hour mode -h- or empty time mode Et as a time-based and cycle-controlled lubrication system according to the values set in PRO menu.

7.1 Pin assignment - time control

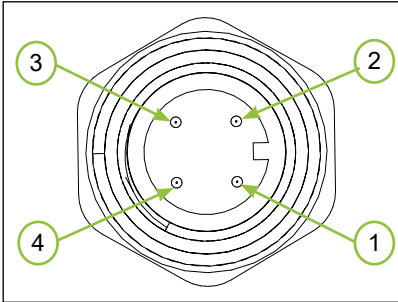

PIN assignment - time control		
PIN	Assignment	Colour
1	+24 V DC	brown
2	unallocated	white
3	ground	blue
4	output signal	black
Type: M12x1 female connector; 4-pin, A-coded		

LUB-S-V can be switched off completely by switching off the supply voltage. Its settings will not be lost: the integrated microelectronics automatically store the remaining time until the next scheduled lubrication cycle. After reapplying the supply voltage LUB-S-V automatically checks itself and continues to operate according to the set values.

- ⓘ After a long standstill of LUB-S-V a "quick check" is recommended (chapter 6.3.8).
- ⓘ The output signal at PIN 4 can be tapped for further processing (e.g. indicator light or external control). The maximum permissible current output must not exceed $I_{max} < 20\text{mA}$. No inductive load (e.g. relay) may be connected!

7.2 Output signals and LCD messages - time control

LCD	Description	Output Signal (PIN 4)	Chapter
OFF	switched off	low, permanent	7.3
On	ready for operation	high, permanent	
E1	cartridge empty	0,5Hz square wave signal, permanent	
E2	overload	low, permanent	
E3	undervoltage	low, permanent	
E4	fatal error	low, permanent	

7.3 Output signals at PIN 4 - time control

LUB-S-V provides two output signals in hour mode -h (factory setting) via the electrical interface. If required, the operating states of LUB-S-V can be processed externally. Basically, the output signals can only be sampled and must not be subjected to inductive loads or low ohmic loads. Besides LCD and LED this also allows a status control from a distance.

Output signal high level (+24 V) at PIN 4:

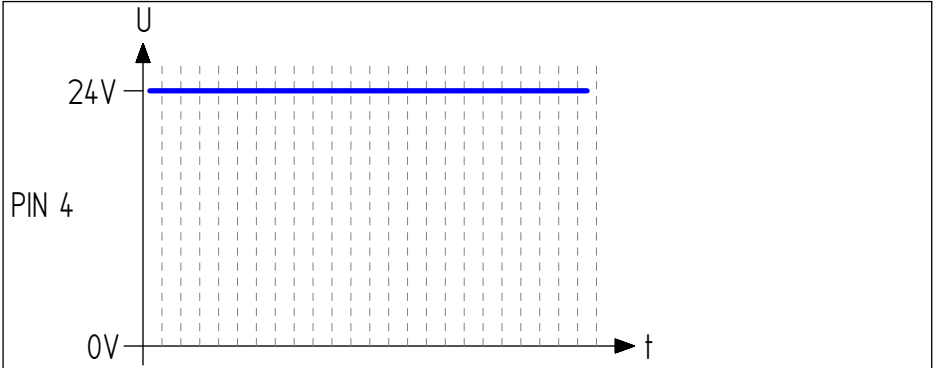

Description:

A permanently and continuously present high level (+24 V) at PIN 4 means that LUB-S-V is ready for operation and there is no error. LUB-S-V will operate according to the settings made and will accordingly convey lubricant from the cartridge to the outlet.

Output signal low level (0 V) at PIN 4:

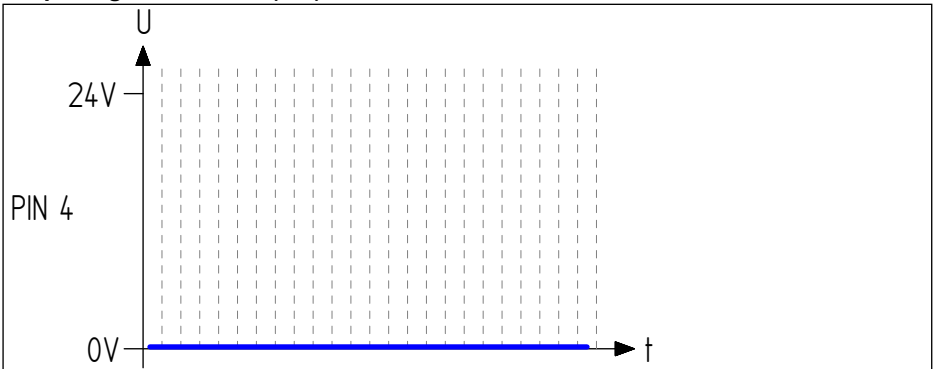

Description:

A permanent low level (0V) at PIN 4 means that LUB-S-V is either switched off or - if it is switched on - an error occurred. The error must be read out from the LCD of LUB-S-V (chapter 6.4). LUB-S-V does not pump lubricant!

8. Input and output signals - external control (PLC)

To command LUB-S-V via an external controller (PLC) it is necessary to switch LUB-S-V to pulse control mode PUL in PRO menu (chapter 6.3.7).

In pulse control mode LUB-S-V operates as a pulse-controlled lubrication system only if unalterable input signals (high level) are transmitted from the PLC to LUB-S-V via PIN 2 in a defined sequence. LUB-S-V signals the respective status to the PLC via high/low levels which can be tapped off at PIN 4 and thus enables comprehensive control or, by suitable programming of the PLC, differentiated evaluation of the different states. To integrate LUB-S-V into an external control one input and one output must be provided on the control side.

8.1 Pin assignment - external control (PLC)

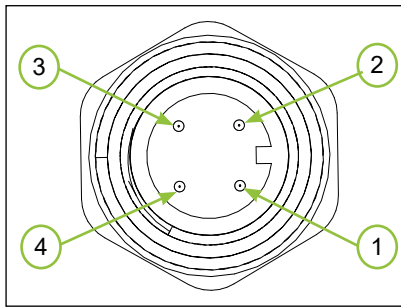

PIN assignment (PLC)		
PIN	Assignment	Colour
1	+24 V DC	brown
2	Input Signal PLC→LUB-S-V	white
3	Ground	blue
4	Output Signal LUB-S-V→PLC	black
Type: M12x1 female connector; 4-pin, A-coded		

To electrically connect LUB-S-V to the PLC of your machine the device provides a 4-pin interface which is designed as a standard industrial M12x1 plug connection.

① LUB-S-V can be switched off completely in pulse control mode by switching off the supply voltage. The settings made are not lost. After reapplying the supply voltage LUB-S-V checks itself automatically but only operates after receiving an input signal from the PLC.

① To operate LUB-S-V via an external controller (PLC) in pulse control mode a program corresponding to the communication protocol must be created in the PLC. A basic flowchart for commanding LUB-S-V can be found in the appendix (chapter 11.4).

① The output signal at PIN 4 can be tapped for further processing (e.g. indicator light or external control). The maximum permissible current output must not exceed $I_{max} < 20\text{mA}$. No inductive load (e.g. relay) may be connected!

① After a long standstill of LUB-S-V a "quick check" is recommended (chapter 6.3.6). Alternatively, a certain number of dispenses can be triggered via the PLC (chapter 8.2).

8.2 Input signals - external control (PLC)

LUB-S-V provides the following unalterably defined control signals (input signals) which must be transmitted from the PLC to LUB-S-V via PIN 2 of the electrical M12x1 interface as high level (+24 V DC).

The control signals must be generated as high level (+24 V) by the external controller (PLC) over certain times with a tolerance of +/- 0.1 seconds.

Signal length in seconds	Description	Function	Chapter
2 high	Signal 2 seconds	1 stroke	8.2.1
12 high	Signal 12 seconds	FIL function	8.2.2
14 high	Signal 14 seconds	Error acknowledgement	8.2.3

ⓘ LUB-S-V in pulse control mode PUL only processes the control signals listed in the table up to a maximum length of 14 seconds. If a high level (+24 V DC) exceeds the defined tolerance level, LUB-S-V does not react. If a high level (+24 V DC) is applied to PIN 2 of the electrical interface for longer than 15 seconds the LCD will display --- and LUB-S-V does not react.

8.2.1 Control signal 2 seconds

The control signal 2 seconds triggers a single dispensing process. After a specified pause time this control signal can be repeated or another control signal can be sent. The operating states are output by LUB-S-V via PIN 4 as a high/low level and must be tapped and processed accordingly by the PLC.

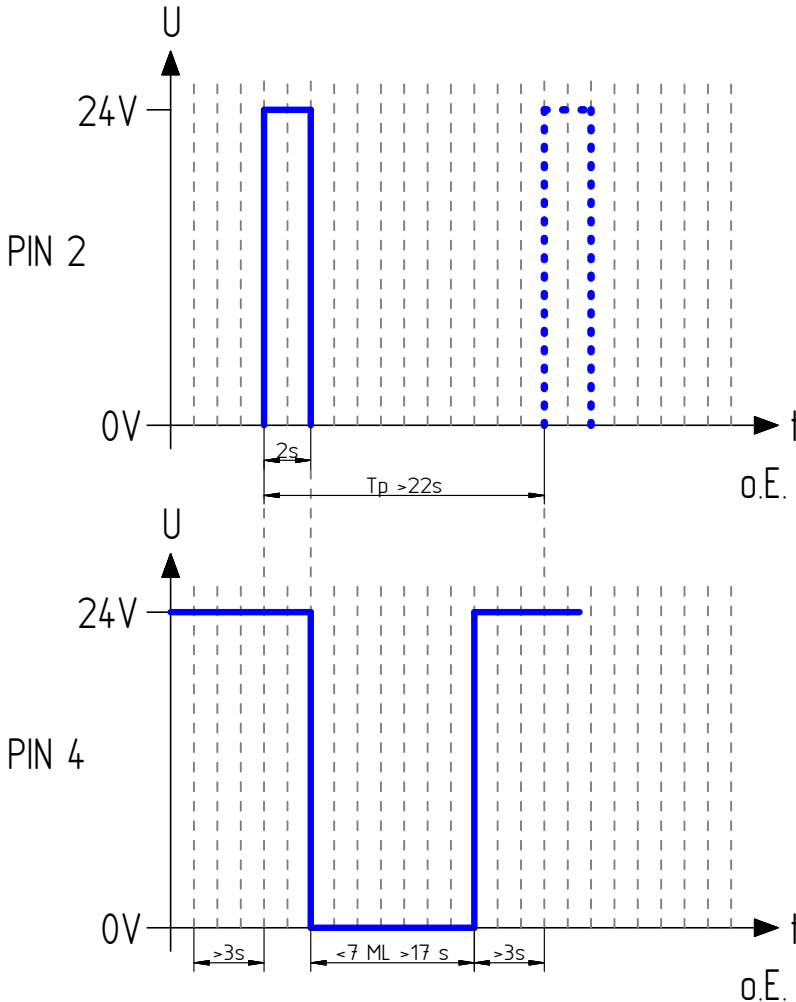

T_p: Pause time
ML: Motor running time

Description:

✓LUB-S-V is properly connected to an external controller via the electrical interface and connected to the power supply.

✓Pulse control mode is activated on LUB-S-V and PUL is displayed on the LCD.

✓There are no errors; LUB-S-V is ready for operation; the green LED in the LCD flashes once every 5 seconds.

✦ LUB-S-V sends a permanent output signal (high level) to PIN 4 which indicates to the external control (PLC) that it is ready for operation. This output signal must be permanently and continuously present for >3 seconds to control LUB-S-V by a PLC.

✦ The control signal 2 seconds with a signal length of 2 (1.9 ... 2.1) seconds high level can be sent to LUB-S-V from the external control (PLC).

✦ While PIN 2 of LUB-S-V receives a high level input signal from the external controller (PLC) PUL is flashing in the LCD.

✦ Immediately after the control signal drops the motor run (ML) of LUB-S-V starts and 0.16 cm³ lubricant is conveyed to the outlet. Simultaneously, LUB-S-V sends a low level output signal to the external controller (PLC) to confirm the duration of the motor run (ML).

✦ The motor running time (ML) depends on various conditions, including the present or built up counterpressure in the hydraulic system and the temperature. The motor running time (ML) is 7...17 seconds.

✦ While the engine is running, the green LED in the LCD lights up and a numerical value of 1...50 is displayed in the LCD. It indicates the approximate back pressure in bar.

✦ At the end of an error-free and successful motor run (ML) the output signal at LUB-S-V changes from a low level to a high level.

ⓘ A new control signal can be sent from the external controller (PLC) at the earliest of >3 seconds after the motor run ended error-free and successfully. In the meantime, LUB-S-V does not process any control signals.

ⓘ In order to ensure a reliable and unambiguous recognition of the control signal a pause must be observed. The control signal 2 seconds requires a pause time (Tp) of at least 22 seconds between two identical or different control signals.

ⓘ If the integrated microelectronics of LUB-S-V have detected an error during or immediately after the motor run (ML), this is transmitted to the external controller (PLC) by the corresponding output signal (chap. 8.3). The error is additionally visualized by the correspondent LCD display with a permanently red flashing LED (section 6.4).

8.2.2 Control signal 12 seconds

The control signal 12 seconds triggers the FIL function (section 6.3.12) by the external control. A total of 40 dispensing operations are carried out automatically one after the other. After a certain pause time this control signal can be repeated or another control signal can be sent. The operating states are output by LUB-S-V via PIN 4 as high/low levels and must be tapped and processed accordingly by the PLC.

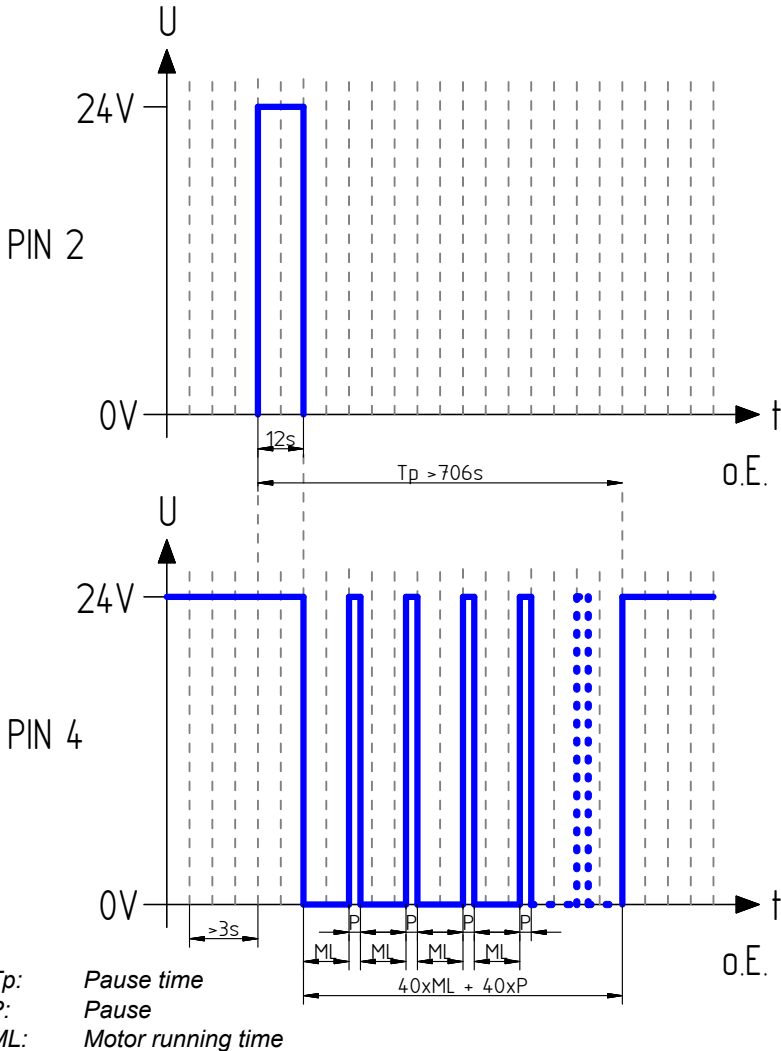

Description:

- ✓ LUB-S-V is properly connected to an external controller via the electrical interface and connected to the power supply.
- ✓ Pulse control mode is activated on LUB-S-V and PUL is displayed on the LCD.
- ✓ There are no errors; LUB-S-V is ready for operation; the green LED in the LCD flashes once every 5 seconds.

✦ LUB-S-V sends a permanent output signal (high level) to PIN 4 which indicates to the external control (PLC) that it is ready for operation. This output signal must be permanently and continuously present for >3 seconds. This condition must be fulfilled to control LUB-S-V by a PLC.

✦ The control signal 12 seconds with a signal length of 12 (11.9 ... 12.1) seconds high level can be sent to LUB-S-V from the external control (PLC).

✦ While PIN 2 of LUB-S-V receives a high level input signal from the external controller (PLC) PUL is flashing in the LCD.

✦ Immediately after the control signal drops the motor run (ML) of LUB-S-V starts and 0.16 cm³ lubricant is conveyed to the outlet. Simultaneously, LUB-S-V sends a low level output signal to the external controller (PLC) to confirm the duration of the motor run (ML).

✦ The motor running time (ML) depends on various conditions, including the present or built up counterpressure in the hydraulic system and the temperature. The motor running time (ML) is 7...17 seconds.

✦ While the engine is running, the green LED in the LCD lights up and a numerical value of 1...50 is displayed in the LCD. It indicates the approximate back pressure in bar.

✦ At the end of an error-free and successful motor run (ML) the output signal at LUB-S-V changes from a low level to a high level for a short pause time P = 0.5 seconds.

✦ A total of 40 engine runs and dispenses will take place immediately one after the other. $40 \times 0.16 \text{ cm}^3 = 6.4 \text{ cm}^3$ lubricant is conveyed from the cartridge to the outlet.

ⓘ A new control signal can be sent from the external controller (PLC) at the earliest of >3 seconds after the motor run ended error-free and successfully. In the meantime, LUB-S-V does not process any control signals.

ⓘ In order to ensure a reliable and unambiguous recognition of the control signal a pause must be observed. The control signal 12 seconds requires a pause time (Tp) of at least 22 seconds between two identical or different control signals.

ⓘ If the integrated microelectronics of LUB-S-V have detected an error during or immediately after the motor run (ML), this is transmitted to the external controller (PLC) by the corresponding output signal (chap. 8.3). The error is additionally visualized by the correspondent LCD display with a permanently red flashing LED (section 6.4).

8.2.3 Control signal 14 seconds

The control signal 14 seconds is used to acknowledge error messages of errors E2 and E3. It is the only control signal that LUB-S-V can process when a low level output signal is sent. Regardless of the basic principle of remotely acknowledging an error it is essential to identify and eliminate the cause when an error message is present.

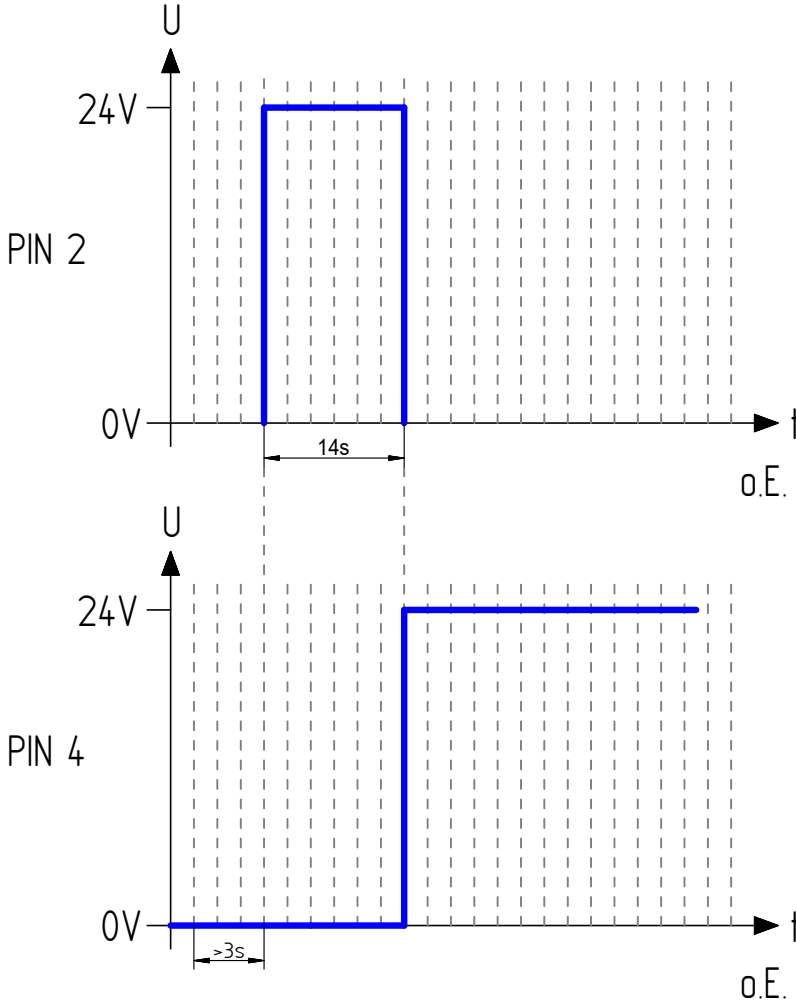

Description:

✓LUB-S-V is properly connected to an external controller via the electrical interface and connected to the power supply.

✓Pulse control mode is activated on LUB-S-V and PUL is displayed on the LCD.

✓There are no errors; LUB-S-V is ready for operation; the green LED in the LCD flashes once every 5 seconds.

✦ LUB-S-V sends a permanent output signal (high level) to PIN 4 which indicates to the external control (PLC) that it is ready for operation. This output signal must be permanently and continuously present for >3 seconds to control LUB-S-V by a PLC.

✦ The control signal 14 seconds with a signal length of 14 (13.9 ... 14.1) seconds high level can be sent to LUB-S-V from the external control (PLC).

✦ When the control signal ends the integrated microelectronics of LUB-S-V will automatically check itself:

+ If this internal check is **successful**, the output signal at LUB-S-V changes from a low level to a high level; error E2 or E3 is thus acknowledged and LUB-S-V is ready for operation again. The LCD briefly displays CLR and then PUL.

- If this internal check is **not successful**, LUB-S-V continues to send a low level output signal. The error (E4) is still present. The error is still displayed in the LCD, the red LED continues to flash permanently. For further measures in this case: chap. 6.4.

ⓘ A new control signal can be sent from the external controller (PLC) at the earliest of >3 seconds after the motor run ended error-free and successfully. In the meantime, LUB-S-V does not process any control signals.

ⓘ Regardless of the basic principle of remotely acknowledging an error, it is essential to identify and eliminate the cause when an error message is occurs.

8.3 Output signals/LCD messages - external control (PLC)

LCD	Description	Output signal (PIN 4)	Chapter
OFF	switched off	low, permanent	6.3.3
PUL	ready for operation	high, permanent	8
PUL flashing	received control signal	high, permanent	8
01...50	dispensing process	low, 10...18 seconds	8
E1	cartridge empty	0,5Hz square wave signal, permanent	8.3.1
E1	cartridge error	low, permanent	8.3.2
E2	overload	low, permanent	8.3.3
E3	undervoltage	low, permanent	8.3.4
E4	fatal error	low, permanent	8.3.5

8.3.1 Fehler E1 (Leerstand) - Externe Steuerung (PLC)

The integrated microelectronics of LUB-S-V is equipped with an automatic counter which counts the number of dispensing operations after a new and full cartridge has been fitted. For a cartridge with 125 ml lubricant there are 780 strokes, for a cartridge with 250 ml lubricant there are 1560 strokes in total. The small mathematical difference is considered to prevent air from entering into the hydraulic system. This ensures that the empty status message (error E1) is transmitted to the external control (PLC) in time. For this purpose, a separate, unique output signal is provided which can be easily and reliably detected by the external control (PLC).

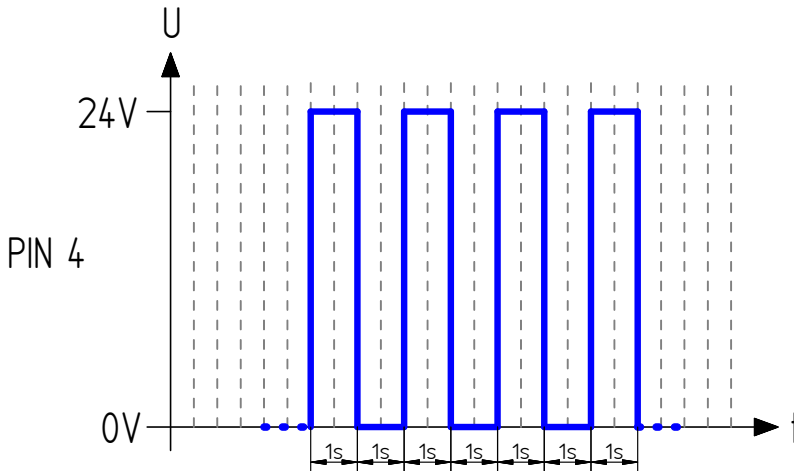

Description:

- ✓LUB-S-V is properly connected to an external controller via the electrical interface and connected to the power supply.
- ✓Pulse control mode PUL is activated on LUB-S-V, E1 is displayed in the LCD and the red LED lights up.

- ✦ Error E1 (empty state signal) can only occur immediately after a dispense.
- ✦ Error E1 (empty state signal) must not and cannot be acknowledged. Remedial action is described in chapters 6.4 and 9.2.
- ✦ When removing the cartridge from an active device the display shows a cartridge symbol (chapter 6.4). Additionally, LUB-S-V sends a permanent square wave signal as output signal to PIN 4.

ⓘ LUB-S-V does not process any control signals until all errors have been eliminated.

The transition of the output signals when changing a cartridge on LUB-S-V in switched-on state is shown and described below:

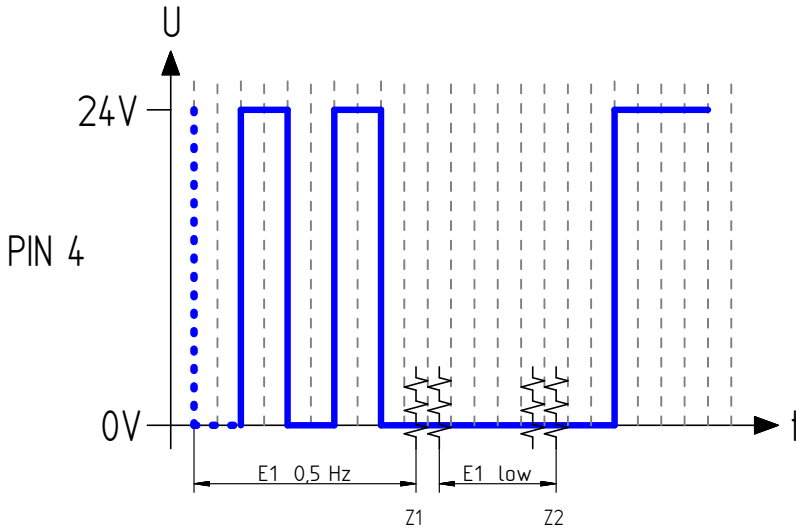

- Z1: *Entfernen der leeren Kartusche*
 Z2: *Aufschauben der neuen Kartusche*

Description:

- ✓ LUB-S-V is properly connected to an external controller via the electrical interface and connected to the power supply.
- ✓ Pulse control mode PUL is activated on LUB-S-V, E1 is displayed in the LCD and the red LED lights up.

✦ The empty cartridge is detected after a dispense, the output signal of LUB-S-V is initially a 0.5Hz square wave signal (empty state signal) (0/+24 V).

✦ Z1 indicates the period of removing the empty cartridge. The output signal of LUB-S-V now changes from a 0.5Hz square wave signal to a permanent low signal (0V). A cartridge error is displayed (chapter 8.3.2).

✦ Z2 indicates the period of screwing on a new, full cartridge. The output signal of LUB-S-V now changes from a permanent low signal (0V) to a permanent high signal (+24V). In this way LUB-S-V signals to the external controller (PLC) that it is ready for operation again.

✦ If the empty state signal has occurred during the execution of the control signal 12 seconds the outstanding strokes are continued after the new cartridge has been screwed on.

ⓘ LUB-S-V does not process any control signals until all errors have been eliminated.

8.3.2 Error E1 (cartridge error) - external control (PLC)

Error E1 (cartridge error) indicates that no cartridge has been screwed onto LUB-S-V. The cartridge sensor installed on top of LUB-S-V detects whether a cartridge is properly screwed onto LUB-S-V but does not detect the capacity of the cartridge or lubricant type.

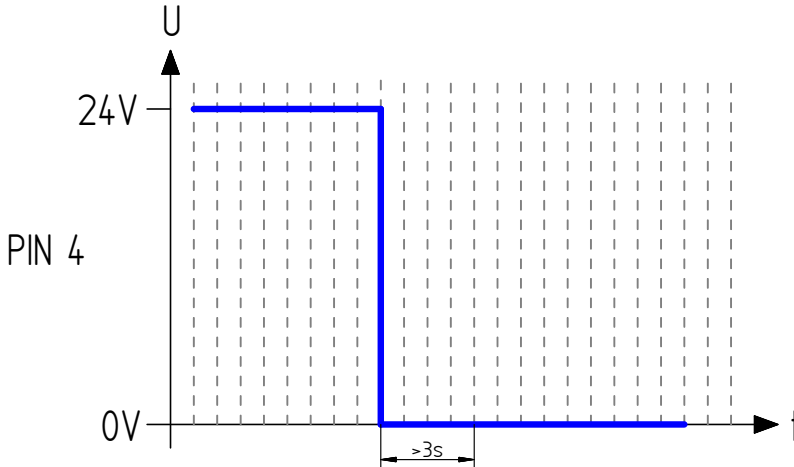

Description:

- ✓ LUB-S-V is properly connected to an external controller via the electrical interface and connected to the power supply.
- ✓ Pulse control mode PUL is activated on LUB-S-V, E1 is displayed in the LCD and the red LED lights up.

- ✦ Error E1 (cartridge error) must not and cannot be acknowledged. Remedial action is described in chapter 9.2.
- ✦ Error E1 (cartridge error) interrupts current dispensing operations on LUB-S-V.
- ✦ LUB-S-V sends a permanent low level (0 V) as output signal to PIN 4 until a cartridge is properly screwed on with LUB-S-V switched on.

ⓘ LUB-S-V does not process control signals until all errors have been eliminated.



NOTICE

A used lubricant cartridge must not be replaced on LUB-S-V as the integrated stroke counter of LUB-S-V is automatically reset by the cartridge sensor after a cartridge has been removed.

- Only use full lubricant cartridges.

8.3.3 Error E2 (overload) - external control (PLC)

Error E2 (overload) signals a hydraulic overload during a dispensing process, e.g. if the maximum pressure is exceeded.

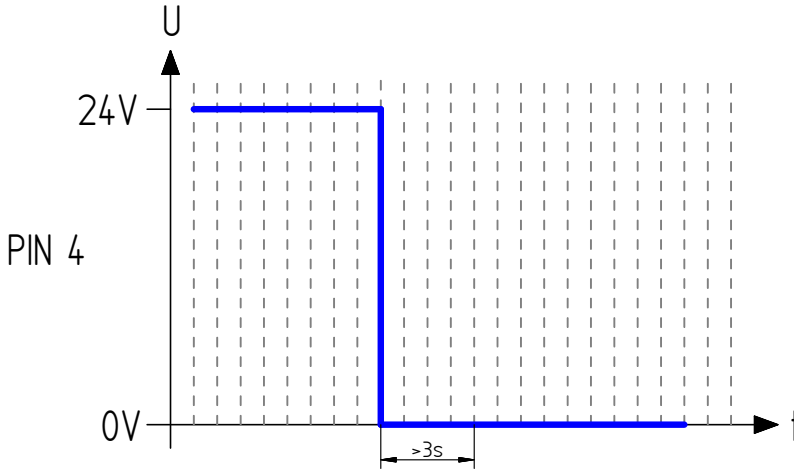

Description:

- ✓LUB-S-V is properly connected to an external controller via the electrical interface and connected to the power supply.
- ✓LUB-S-V has been successfully controlled by the external control (PLC) immediately before the occurrence of error E2 and has (attempted to) perform a dispensing operation.
- ✓Pulse control mode PUL is activated on LUB-S-V, E2 is displayed in the LCD and the red LED lights up.

✦ When the maximum permissible pressure is reached during or after a dispense, LUB-S-V sends a permanent output signal as low level (0 V) to PIN 4 for external control (PLC).

✦ Error E2 (overload) must be acknowledged with the control signal 14 seconds (chapter 8.2.3) after elimination of the cause(s).

ⓘ LUB-S-V does not process any control signals until all errors have been eliminated.

8.3.4 Error E3 (undervoltage) - external control (PLC)

Error E3 (undervoltage) indicates that the power supply is not within the specified parameters.

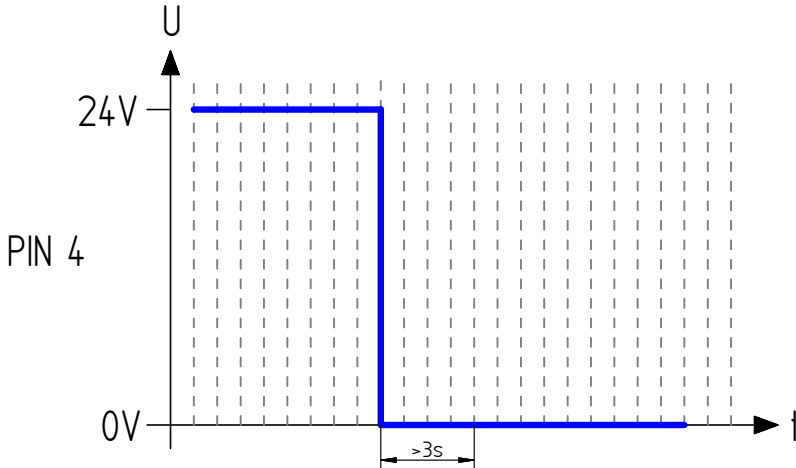

Description:

✓LUB-S-V is properly connected to an external controller via the electrical interface and connected to the power supply.

✓Pulse control mode PUL is activated on LUB-S-V, E3 is displayed in the LCD and the red LED lights up.

✦ If the supply voltage is too low, LUB-S-V sends a permanent output signal as low level (0 V) to PIN 4 for external control (PLC).

✦ Error E3 (undervoltage) must be acknowledged with the control signal 14 seconds (chapter 8.2.3) after elimination of the cause(s).

ⓘ LUB-S-V does not process any control signals until all errors have been eliminated.

8.3.5 Error E4 (fatal error) - external control (PLC)

Error E4 (fatal error) indicates that the integrated microelectronics has detected a critical error and that LUB-S-V is not operating within the valid parameters. The cause can be mechanical, electronic or any other influencing variable.

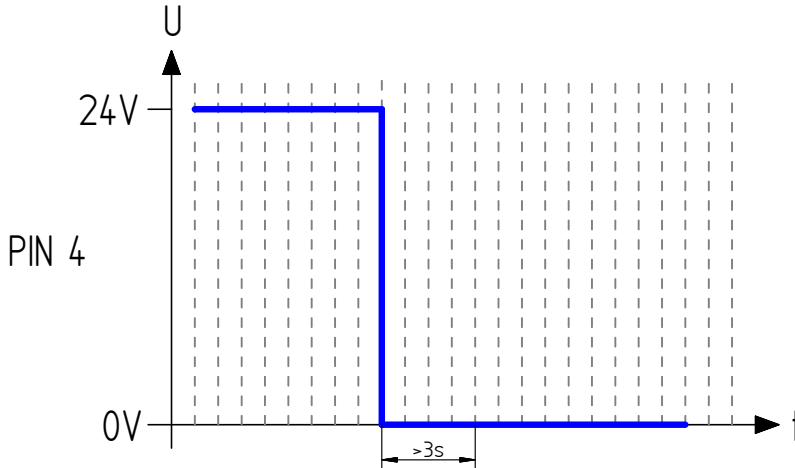

Description:

- ✓ LUB-S-V is properly connected to an external controller via the electrical interface and connected to the power supply.
- ✓ Pulse control mode PUL is activated on LUB-S-V, E4 is displayed in the LCD and the red LED lights up.

- ✦ In an (internal) diagnosis, the critical (rare) error E4 has been detected.
- ✦ Error E4 cannot be corrected by you on site and cannot be acknowledged by you on LUB-S-V!
- ✦ Remove LUB-S-V with the lubricant cartridge screwed on and return the complete lubrication system to the manufacturer with a detailed description of the fault.

ⓘ Do not open LUB-S-V without authorization! Observe the relevant notes and regulations for proper use (section 2.5) and warranty (section 2.6).

9. Maintenance and disposal

- ✦ Before starting any maintenance work, inform yourself about the general safety instructions (see chapter 2) and observe the relevant local and operational safety regulations.
- ✦ Do not deactivate any protective device without authorization!

9.1 Maintenance schedule

The following maintenance schedule must be observed for LUB-S-V:

Maintenance	Commissioning	After 500 hours or after 3 months	Annually	If required
Cleaning	X	X	X	X*
Visual check	X	X	X	X*
Cartridge change	X**		X***	X*

* Depending on operating conditions and lubricant consumption

** Depending on delivery status (ordered version)

*** after 2 years at the latest

9.1.1 Visual check

- ✦ Check the entire lubrication system (LUB-S-V and any connected accessories including tubes and distributors) for external damage (e.g. loose or loosened tubes) by a thorough and conscientious visual inspection.
- ✦ Check the condition of the lubrication point for correct supply of lubricant.
- ✦ Replace damaged or defective parts immediately to ensure permanent lubrication.
- ✦ Check the filling level of the cartridge on LUB-S-V.
- ✦ Check possible error messages on LUB-S-V and remedy the causes accordingly.

9.1.2 Cleaning





- ✦ Clean LUB-S-V from dirt using suitable cleaning agents (e.g. absorbent towels, cloths).

	NOTICE
	<p>Compressed air can damage the seals of LUB-S-V as well as transport dirt and foreign bodies into LUB-S-V or the lubricant.</p> <ul style="list-style-type: none">• Do not use compressed air to clean LUB-S-V.

9.1.3 Recommissioning after maintenance

- ✦ Reinstall all safety devices and make sure that no tools remain in the danger area.
- ✦ Check if LUB-S-V is switched on.
- ✦ Carry out a "Quick Check" (test run) using the RUN command (section 6.3.8).

9.2 Cartridge change

	<p style="text-align: center;">NOTICE</p> <p>A used lubricant cartridge must not be replaced on LUB-S-V as the integrated stroke counter of LUB-S-V is automatically reset by the cartridge sensor after a cartridge has been removed.</p> <ul style="list-style-type: none"> • Only use full lubricant cartridges.
	<p style="text-align: center;">NOTICE</p> <p>Only use original lubricant cartridges with lubricant approved by the manufacturer.</p> <ul style="list-style-type: none"> • Observe the maximum shelf life of lubricant filled in cartridges.
	<p style="text-align: center;">NOTICE</p> <p>It is not possible to refill empty or opened lubricant cartridges.</p>
	<p style="text-align: center;">NOTICE</p> <p>Make sure you use the same lubricant in the new cartridge that is already in use.</p> <ul style="list-style-type: none"> • Compare the data on the lubricant cartridge.

Changing the lubricant cartridge of LUB-S-V is very easy.

The cartridge needs to be changed if it is empty or if the service life of the lubricant has been exceeded. The cartridge can be changed during normal operation of LUB-S-V. Besides the cartridge change no further action is needed.

✓LUB-S-V has a fault (error E1); the red LED flashes every 5 seconds.

1



Unscrew empty cartridge

✦ Turn the empty cartridge counterclockwise from LUB-S-V and dispose it properly afterwards.

ⓘ Pay attention to cleanliness during work. Make sure that dirt and foreign bodies do not get into the lubricant inlet. If necessary, carry out cleaning work beforehand (chapter 9.1.2).

2



Mount new lubricant cartridge

✦ Place the full lubricant cartridge onto LUB-S-V.

✦ Turn the lubricant cartridge clockwise onto LUB-S-V.

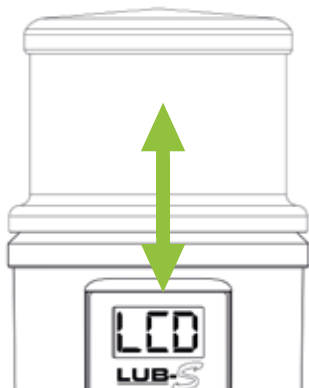

ⓘ The end position is reached after 2 full rotations when the label of the lubricant cartridge is aligned with the front foil of LUB-S-V.

- ✦ Carry out the work as described above.
- ➡ If an error was displayed in the LCD before changing the cartridge, the message will now disappear, as will the flashing red LED. A separate confirmation is not necessary. The green LED flashes briefly every 5 seconds.
- ➡ LUB-S-V automatically returns to the last active mode (ON or OFF).
- ⓘ If the empty state of the cartridge (error E1) was reached during a dispensing cycle, it is interrupted and continued automatically after completing the work explained above.

9.3 Disposal

- ✦ When disposing LUB-S-V and empty or opened cartridges, follow the relevant national regulations in force.
- ✦ When disposing LUB-S-V observe the relevant safety data sheets and disposal instructions for the individual components.
- ⓘ It is not possible to refill empty lubricant cartridges.

10. Released accessories

The present LUB-S-V can be considerably extended by the extensive system and accessory program from use as a single point lubricator. This may necessitate changes to the factory and/or the default settings of LUB-S-V to ensure reliable and proper operation of LUB-S-V combined with the hydraulically connected accessories.

Amongst others, cartridges filled with different lubricants, brackets, splitters, progressive distributors and thread adapters are available.

For more information please contact the manufacturer or visit its website www.G-LUBE.com.

10.1 Lubricants

Only use lubricants approved by the manufacturer Gruetzner GmbH in the original cartridges developed and manufactured exclusively for LUB-S-V.

	NOTICE
	The lubricant used in each case differs according to the application. The respective designation can be found on the label of the cartridge.

Further information on lubricants, documentation and safety data sheets can be obtained directly from the manufacturer Gruetzner GmbH.

10.2 Tube lengths

Generally it is recommended to install LUB-S-V as close as possible to the consumer (lubrication point). Ideally, this should be done directly at or on the lubrication point. In cases where this is not possible due to the installation space or for reasons of reachability or accessibility, tubes can also be used between LUB-S-V and the lubrication point (or distributor).

The tube length shall not exceed 4 meters, the inner tube diameter shall not be lower than 4 mm. The maximum tube length depends on a wide range of parameters such as temperature, application and viscosity of the lubricant used.

11. Appendix 11.1 Dimension sheet and installation dimensions

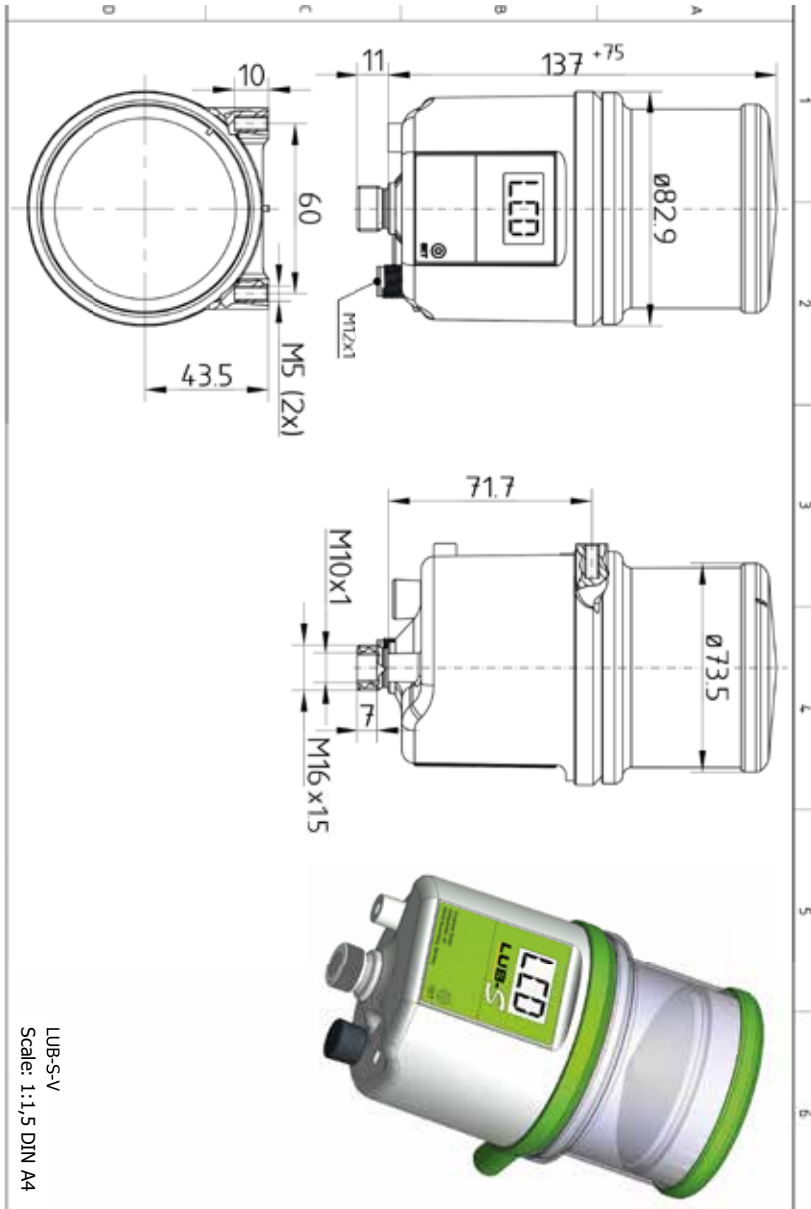

11.2 EC/EU Declaration of conformity

EC declaration of conformity



**Declaration of conformity
according to EC machinery directive 2006/42/EC as of 17. May 2006**



The manufacturer or authorised representative*

Gruetzner GmbH, Kohlenhofstr. 60, 90443 Nuremberg, Germany

hereby declares that the following lubrication systems

Product designation: LUB-S

Type designation: LUB-S-V (24 VDC power supply), **LUB-S-B** (battery powered)

comply with the essential requires of EC directive 2006/42/EC.

The following harmonized standards have been applied:

EN 12100:2011 Safety of machines

Additionally the systems comply with the regulations for electromagnetic compability according to 2004/108/EC.

The following harmonized standards have been applied:

EN 61000-6-2, EN 61000-6-4 electromagnetic compability

Authorised representative for the compilation of technical documents:

Volker Grütznér, CEO, Gruetzner GmbH, Kohlenhofstr. 60, 90443 Nuremberg, Germany

Nuremberg, 01.10.2019



Volker Grütznér, CEO

*must be based within the EU

Gruetzner GmbH

Kohlenhofstr. 60

90443 Nuremberg, Germany

Tel: +49 911 277399-0

Fax: +49 911 277399-99

info@G-LUBE.com

www.G-LUBE.com



GRUETZNER
AUTOMATIC LUBRICATION



11.3 Spare parts

Art. no.	Designation	Application

11.4 Flow chart impulse mode PUL

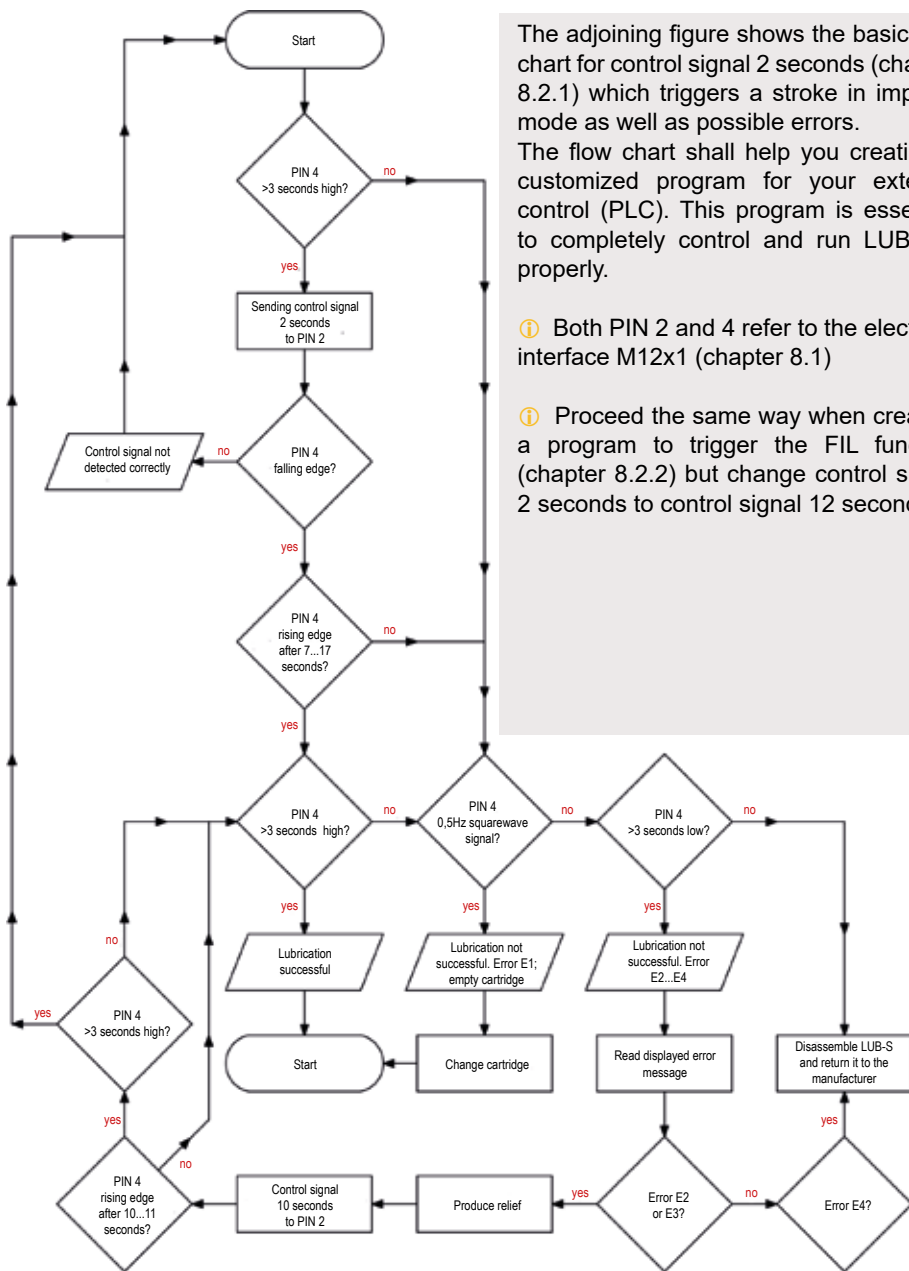

The adjoining figure shows the basic flow chart for control signal 2 seconds (chapter 8.2.1) which triggers a stroke in impulse mode as well as possible errors.

The flow chart shall help you creating a customized program for your external control (PLC). This program is essential to completely control and run LUB-S-V properly.

① Both PIN 2 and 4 refer to the electrical interface M12x1 (chapter 8.1)

① Proceed the same way when creating a program to trigger the FIL function (chapter 8.2.2) but change control signal 2 seconds to control signal 12 seconds.



GRUETZNER
AUTOMATIC LUBRICATION



G LUBE



SOLO LUBE

AUTOMATIC LUBRICATION



LUB 5



LUBRICUS

Gruetzner GmbH

Dagobertstr. 15 • D - 90431 Nuremberg, Germany

Tel. +49 911 277 399 0 • info@G-LUBE.com • www.G-LUBE.com