

# Oil-Applicators

Precise dosing and supply  
of the lubricant

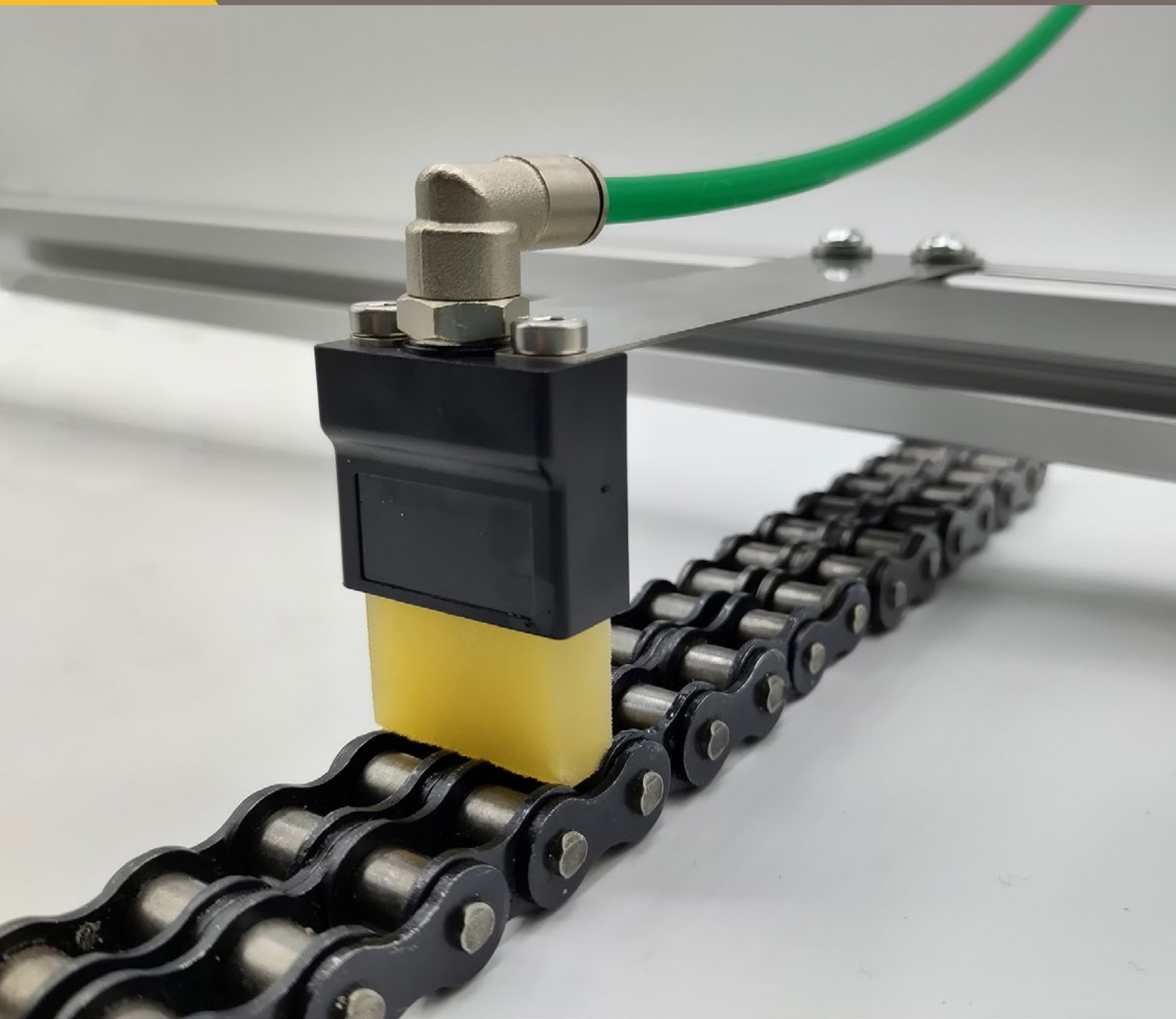

**GRUETZNER**  
MAINTENANCE EQUIPMENT

# Functionality

Applicators apply oil evenly and purposefully to chains and are characterised by special resistance: The application surface consists of 100% low-wear PU foam. The durability of the material not only enables use with high-speed chains up to 5 m/s, which cannot be lubricated by brushes or pinions. Sensitive areas such as food production also benefit from the extremely low abrasion, as contamination of the environment can be virtually ruled out.

# Advantages



## Durable

Longer service life than brushes



## Leak-proof

Built-in non-return valves



## Easy assembly

Pre-assembled spring plate and hose connector



## Flexible

4 sizes,  
suitable for most chain widths

# Technical Data

### Operating temperature

-30 °C to +80 °C  
(-22 °F to +176 °F)

### Max. Speed

5 m/s

### Lubricant

Oil

### Viscosity range (40 °C)

15 ... 320 cSt

### Material Housing

ABS, Stainless steel

### Material Applicator

PU foam

### Sizes

30 mm, Art. no. GAT-AP-30  
45 mm, Art. no. GAT-AP-45  
60 mm, Art. no. GAT-AP-60  
85 mm, Art. no. GAT-AP-85

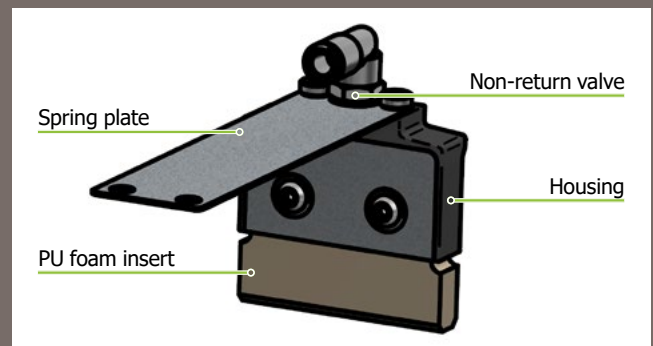

# Exchange

The various PU foam inserts are available as spare parts. In case of wear, these can be re-ordered at low cost without having to replace the housing and mounting material. For quick and easy replacement, only the cover plate of the housing has to be removed.

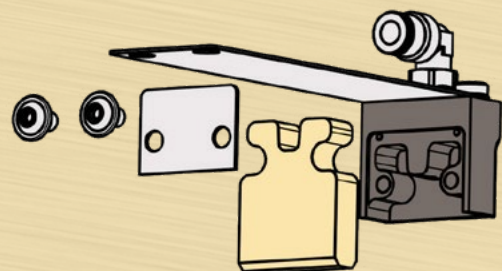

**GRUETZNER**  
MAINTENANCE EQUIPMENT

**Gruetzner GmbH**  
Dagobertstr. 15 • 90431 Nuremberg, GER  
tel. +49 911 277 399 0  
info@G-LUBE.com • www.G-LUBE.com