

	Error E4 (device error)	Disassemble LUB-S-V and return it to the manufacturer with the cartridge and a description of the fault.
--	----------------------------	--

① LUB-S-V will not deliver any lubricant and does not process any control signals until all errors have been eliminated.

5.2 Actions with the activation and programming key (APK)

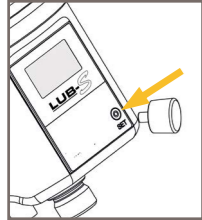

- Remove the APK from the underside of LUB-S-V.
- Place the APK on the action area on the front of LUB-S-V.
- Remove the APK from the action area as long as the desired menu item is shown in the display.

5.3 Settings menu

The Settings menu allows you to change the operating mode and the cartridge size of LUB-S-V. You can switch between hour mode, empty time mode and pulse mode. Being in hour mode, you can change the pause time as well as the number of strokes per lubrication cycle. Running empty time mode, you can change the emptying time in months.

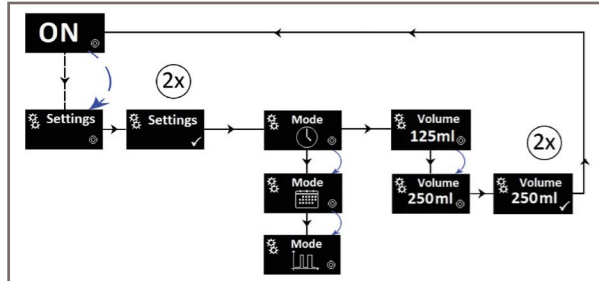

If you would like to change the operating mode, select the Settings menu and move the activation and programming key back to the action area when Mode is displayed. The double circle appears and the three adjustable operating modes are shown alternately in the display. When your desired operating mode is displayed, remove the activation and programming key from the action area.

5.4 PIN assignment

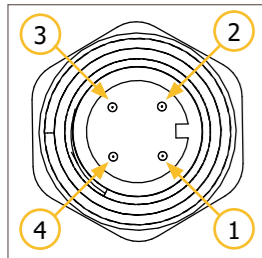

PIN	Assignment	Colour
1	+24 V DC	brown
2	input signal (pulse mode)	white
3	ground	blue
4	output signal	black

Type: M12x1 female connector; 4-pin, A-coded

① Settings made are saved even after the supply voltage is switched off.

5.5 Output signals - hour mode

The output signal at PIN 4 can be tapped for further processing (e.g. indicator light or external control). The maximum permissible current output must not exceed $I_{max} < 20$ mA. No inductive load (e.g. relay) may be connected!

Output signal (PIN 4)	Meaning
0.5 Hz-Square wave signal, permanent	Note N1 Empty cartridge LUB-S-V will not deliver any lubricant!
low, permanent	LUB-S-V is switched off or there is an error (E1, E2, E3, E4). The error can be read on the display. LUB-S-V will not deliver any lubricant!
high, permanent	LUB-S-V is operating correctly

5.6 Input signals - external control (PLC)

To command LUB-S-V via an external controller (PLC) it is necessary to switch LUB-S-V to **pulse mode** in the Settings menu. In pulse mode LUB-S-V operates as a pulse-controlled lubrication system only if unalterable input signals (high level) are transmitted from the PLC to LUB-S-V via PIN 2 in a defined sequence. LUB-S-V signals the respective status to the PLC via high/low levels which can be tapped off at PIN 4.

① To operate LUB-S-V via an external controller (PLC) in pulse mode a program corresponding to the communication protocol must be created in the PLC.

LUB-S-V provides the following unalterably defined control signals (input signals) which must be transmitted from the PLC to LUB-S-V via PIN 2 of the electrical M12x1 interface as high level (+24 V DC). The control signals must be generated as high level (+24 V) by the external controller (PLC) over certain times with a tolerance of +/- 25 ms.

Signal length in ms	Function
100 ms	1 stroke
900 ms	Filling function
1000 ms	Cancel Filling function
1600 ms	Status request
1700 ms	Acknowledge error (E2 and E3)

① LUB-S-V in pulse mode PUL only processes the control signals listed in the table up to a maximum length of 1700 ms. If a high level (+24 V DC) exceeds the defined tolerance level, LUB-S-V does not react.

① LUB-S-V continues to process the signal lengths used by devices between 2019 and 2022! (2 seconds: 1 stroke, 12 seconds: Filling function, 14 seconds: Acknowledge error)
The length of the first signal received determines which control signals it reacts to. A changeover is made by interrupting the voltage for a few seconds.

Control signal 100 ms

Immediately after the control signal drops the motor run of LUB-S-V starts and 0.15 ml lubricant is conveyed to the outlet. At the end of a lubrication stroke, LUB-S-V sends an output signal to PIN 4, which provides information about the past lubrication stroke as well as other states of LUB-S-V for evaluation at a PLC or other external control.

① At the earliest >500 milliseconds after the end of the output signal, a possible next control signal can be sent from the external control (PLC).

5.7 Output signals - external control (PLC)

During the transmission of the output signal, the signaling for information transmission changes several times from a high level to a low level and back again. The output signal is sent with a frequency of $f = 5$ Hz. After sending an output signal, a high level is permanently present at PIN 4.

The following graphic shows an example of an output signal.

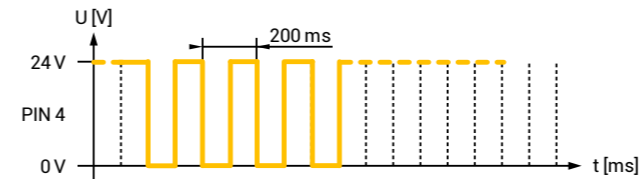

Information about the status of LUB-S-V and about the past motor run can be evaluated via an evaluation of the number of edge changes of the output signal. For the evaluation of the edge changes, the rising edge must always be counted. The counted number of edge changes corresponds to a one-to-one state of LUB-S-V.

Number of edge changes	Meaning
1	Filling function canceled
2	Past lubrication stroke OK
3	Past lubrication stroke OK, cartridge soon empty
4	Overpressure (error E2)
12	Cartridge empty (note N1), no cartridge (error E1)
14	Over-/undervoltage (error E3)
15	Internal device error (error E4)
16	Inadmissible, undefined control signal received

6. Maintenance

NOTICE

A used lubricant cartridge must not be put back on LUB-S-V as the integrated stroke counter of LUB-S-V is automatically reset by the cartridge sensor after a cartridge has been removed. Only use full lubricant cartridges.



Quick start guide LUB-S-V (24 V DC)



1. Product details

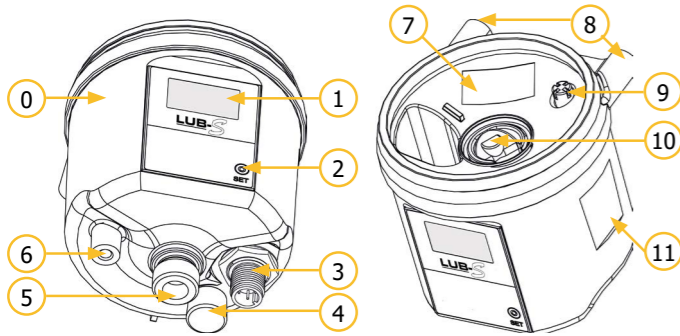

No.	Description
0	LUB-S-V
1	OLED display
2	Operation pad (for actions with the APK)
3	Electric interface M12x1
4	Activation and programming key (APK)
5	Lubricant outlet / M16 male thread for bottom mounting
6	M5 female thread for bottom mounting
7	Serial number of LUB-S-V
8	M5 female thread for rear mounting
9	Cartridge sensor
10	Lubricant inlet with thread for cartridge
11	Nameplate with designation and CE mark

2. Technical data

Housing		
Mounting options	backside: female thread M5 (2x) bottom: f. thread M5(1x), m. thread M16x1.5(1x)	
Max. Torque mounting	3	Nm
Mounting position	any (upright preferred)	
Operating temperature	-15 to +60*	°C
Lubricant and hydraulic		
Number of lubrication points	up to 4 by using splitters* up to 10 by using progressive distributors*	
Max. Pressure	50 (-10%/+15%)	bar
Grease delivery	per stroke	0.15 ml
Electrics		
Operating voltage (DC)	24 (+/- 5%)	V
Protection	0,75 (slow blow)	A
Protection class	IP 54	

* The stated value is down to the individual application and may extensively differ in some cases (depending on the lubricant and further conditions).

This brief instruction of mounting LUB-S-V addresses to experienced users. Please visit www.G-LUBE.com to download the complete user manual including all safety instructions.

3. Mounting

- Remove the yellow protective cap from the top of the lubricant inlet of LUB-S-V. (Fig. 1)
- Unscrew the yellow protective cap counterclockwise from the lubricant outlet on the bottom of of LUB-S-V. Remove the black protective cap from the electrical interface on the bottom of LUB-S-V. (Fig. 2)
- Turn the cap on the lubricant cartridge counterclockwise and pull it off.
- Place the full lubricant cartridge on LUB-S-V. Turn the lubricant cartridge clockwise onto LUB-S-V.

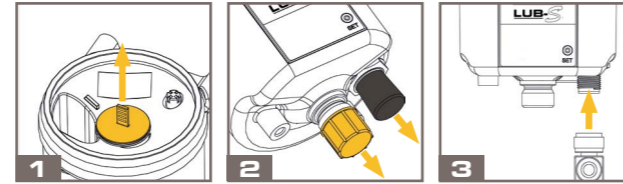

4. Commissioning

Mechanical fastening

Fix LUB-S-V mechanically through the M5 female threads or through the M16x1.5 male thread of the lubricant outlet. Pay particular attention to the maximum tightening torques permissible for the M5 female threads!

Electrical connection

To connect LUB-S-V with an external power supply system add a proper connecting cable to the electrical interface on the bottom of LUB-S-V. (Fig. 3)

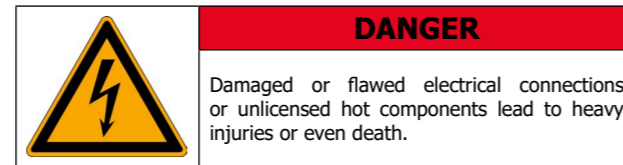

Power on

Execute Filling function

Bleeding of the pump during initial commissioning.

Hydraulic connection

Connect the equipment hydraulically to LUB-S-V. When you connect tubes to LUB-S-V, make sure that tubes and connectors are installed tightly, cleanly and correctly. The tube length shall not exceed 4 meters, the inner tube diameter shall not be lower than 4 mm. Make sure that the end of the tube is cut straight.

ⓘ Ideally, use tubes prefilled with the appropriate lubricant.

Check the settings on LUB-S-V

Check the required values for the lubrication point at the factory settings of LUB-S-V and adjust them if necessary. Factory settings: operating mode=hour mode.

5. Operation and settings

Three operating modes can be selected.

The **hour mode** allows setting the number of strokes per cycle (strokes) within a pause time (Pause) in hours.

Pause times from **1 to 240 hours** and **strokes per cycle** from **1 to 10** can be set.

The **empty time mode** allows the emptying time of the cartridge to be set in months (months).

Emptying times from **1 to 24 months** can be set.

Additionally, LUB-S-V can be embedded into a programmable logic controller (PLC) which sends orders and controls LUB-S-V in **pulse mode**.

Default settings: hour mode

Pause = 6 The pause time between the start of two cycles is 6 hours.
strokes = 1 The number of strokes per cycle is one (1).

Default settings: empty time mode

months = 6 The empty time of the cartridge is 6 months.

Default settings: pulse mode

Pulse mode enables embedding LUB-S-V in an external control (PLC) to command and control the device.

5.1 Menu and display messages

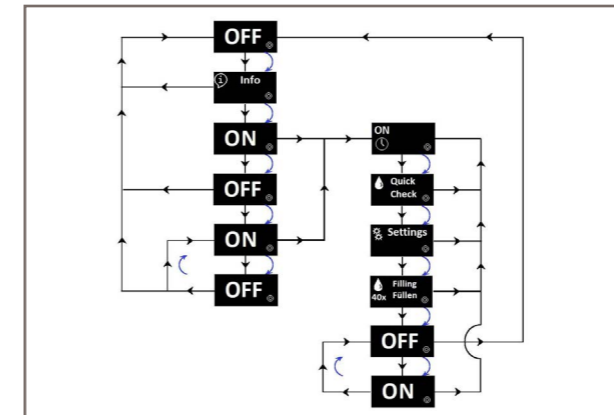

The graphic above illustrates the unchangeable basic flowchart of the LUB-S-V menu navigation as well as the options for branching to submenus.

- ⓘ LUB-S-V can be switched on and off at several points in the menu navigation.
- ⓘ The Info menu provides you with an informative overview of the current LUB-S-V settings.
- ⓘ The Settings menu allows you to change the operating mode, make changes to the LUB-S-V settings - and thus to its dispensing behavior and to adjust the size of the cartridge.
- ⓘ See the table on page 5 for more information on the menu and the sub-items and functions.

Display	Meaning
Selection of the operating mode in the Settings menu	
Mode	Operating mode: hour mode
Mode	Operating mode: empty time mode
Mode	Operating mode: pulse mode
Selection of the settings in the Settings menu	
Pause	Adjustable setting of pause time from 1 to 240 hours (hour mode only)
Hübe strokes	Adjustable setting of number of strokes from 1 to 10 (hour mode only)
Monate months	Adjustable setting of emptying time from 1 to 24 months (empty time mode only)
Volume	Adjustable setting of cartridge size
Quick-Check / Filling	
Quick Check	Back pressure check by special dispensing
Filling Füllen	Bleeding of the pump for example, during initial commissioning
50 max. bar	During Quick Check/Filling, the current back pressure at the outlet is displayed in bar.
20x STOP	Cancel Quick Check/Filling
Displays in the Info menu	
Software N11	Firmware version of LUB-S-V
002700	Number of executed strokes
Errors	Remedy
Error E1 (no cartridge)	Insert original cartridge. No need to acknowledge the error.
Note N1 (empty cartridge)	Insert new original cartridge. No need to acknowledge the error.
Error E2 (overpressure)	Check lubrication point and eliminate the cause. Acknowledge error.
Error E3 (over-/undervoltage)	Check the power supply. Acknowledge error.