

# LUB-S

## User manual LUB-S-V (24 VDC)



**GRUETZNER**  
AUTOMATIC LUBRICATION

## Table of contents

<b>Revision history .....</b>	<b>5</b>
<b>Imprint of the manufacturer.....</b>	<b>5</b>
<b>1. General information about this manual.....</b>	<b>6</b>
1.1 Signal words.....	6
1.2 Warning symbols .....	7
1.3 Structure of the safety instructions.....	7
1.4 Symbols for information.....	8
<b>2. Safety .....</b>	<b>8</b>
2.1 EG/EU Directive.....	8
2.2 Hazards .....	8
2.3 Staff .....	8
2.4 Reasonably predictable misuse.....	9
2.5 Usage for the intended purpose .....	9
2.6 Warranty and liability .....	9
2.7 General safety instructions .....	10
<b>3. Description of function.....</b>	<b>11</b>
3.1 General information.....	11
3.2 Nameplate and designation.....	12
3.3 Scope of delivery.....	12
3.4 Technical data.....	13
<b>4. Transport and storage.....</b>	<b>14</b>
4.1 Packaging.....	14
4.2 Transport.....	14
4.3 Storage .....	14
<b>5. Mounting .....</b>	<b>15</b>
5.1 Preparations.....	15
5.2 Mechanical mounting.....	15
5.3 Mounting height.....	16
5.4 Mounting of the LUB-S.....	17
5.5 Start-up.....	20

<b>6.</b>	<b>Operation and settings.....</b>	<b>21</b>
6.1	General information.....	21
6.2	Menu and display messages .....	24
6.3	Actions with the activation and programming key.....	27
6.3.1	Switching LUB-S on and off .....	29
6.3.2	Get information about the LUB-S.....	31
6.3.3	Perform a Quick-Check.....	33
6.3.4	Set operating mode and cartridge size.....	35
6.3.4.1	Operating mode Setting Lubrication cycle duration ....	38
6.3.4.2	Operating mode Setting Emptying time .....	46
6.3.4.3	Operating mode pulse control.....	53
6.3.5	Activate the Filling-menu .....	54
6.4	Error and information messages on the display.....	56
6.5	Empty level warning.....	57
<b>7.</b>	<b>Output signals – Time control.....</b>	<b>58</b>
7.1	Pin assignment – Time control.....	58
7.2	Output signals – Time control .....	59
<b>8.</b>	<b>Input and output signals – External control (PLC) .....</b>	<b>60</b>
8.1	Pin assignment – External control (PLC).....	60
8.2	Input signals – External control (PLC).....	61
8.2.1	Control/input signal „1 lubrication stroke“.....	63
8.2.2	Control/input signal „Filling“ .....	65
8.2.3	Control/input signal „Cancel filling“ .....	67
8.2.4	Control/input signal „Status request“ .....	68
8.2.5	Control/input signal „Acknowledge error“ .....	69
8.3	Output signals – External control (PLC).....	70
<b>9.</b>	<b>Maintenance and disposal.....</b>	<b>72</b>
9.1	Maintenance schedule .....	72
9.1.3	Visual inspection .....	73
9.1.1	Cleaning .....	73
9.1.2	Recommissioning after maintenance.....	73
9.2	Cartridge change .....	74
9.3	Disposal.....	76
<b>10.</b>	<b>Further notes .....</b>	<b>77</b>
10.1	Lubricants.....	77
10.2	Pipe lengths.....	77

<b>11.</b>	<b>Appendix .....</b>	<b>78</b>
11.1	Dimension sheet and installation dimension.....	78
11.2	EC/EU Declaration of conformity.....	79

The above data and information correspond to the current state of knowledge and our development. However, they do not represent any assurance of properties or a guarantee for the suitability of the products in individual cases. We reserve the right to change the information in this technical data sheet at any time and without prior notice or to make technical changes. The representation in the pictures may differ from the original.

## Revision history

This manual was written in German, all other language versions are translations of this manual.

This user manual is only valid for

**Product:**

Product designation:	Lubricus S (LUB-S)
Product revision:	---

**User manual:**

Date of creation:	05.2022
Revision of the user manual:	1.0
Language:	EN

This document is protected by copyright.

All rights for layout, content, texts and corporate design are reserved by Gruetzner GmbH © 2022. All rights, including those of photomechanical reproduction, duplication and distribution by means of special processes (e.g. data processing, data carriers and data networks), even in part and/or in extracts, are reserved by Gruetzner GmbH. The content and technical specifications are subject to change without notice.

## Imprint of the manufacturer

Adress:

Gruetzner GmbH  
Dagobertstr. 15  
D-90431 Nürnberg  
Tel: +49 (0)911 277 399-0  
Fax: +49 (0)911 277 399-99  
info@G-LUBE.com  
www.G-LUBE.com

Handelsregister beim Amtsgericht Nürnberg HRB 12109

USt-ID: DE 160441123

Geschäftsführung: Volker Grützner

## 1. General information about this manual

This user manual contains all necessary information to use the Lubricus-S in the power supply version, hereinafter referred to as LUB-S, safely and as intended. In the event that supplementary sheets are attached to these instructions, the information and data contained in the supplementary sheets are valid and replace the corresponding information in this user manual. Any contradictory information contained in this user manual thus becomes invalid. If you have any questions regarding special applications, please contact Gruetzner GmbH.

The actual and factual operator must ensure and guarantee that these instructions, including any supplementary sheets, have been read and understood by all persons responsible for the installation, operation or maintenance of the LUB-S. Therefore, keep these instructions in a suitable place, ideally in an easily accessible place, in the surrounding area of the LUB-S.

Inform your colleagues who work in the local area of the machine about safety instructions so that nobody gets hurt.

This manual was written in German, all other language versions are translations of this manual.

### 1.1 Signal words

#### **DANGER**

This signal word points you to an immediate and threatening risk of serious injury or death.

#### **WARNING**

This signal word indicates a potentially imminent danger which can result in serious injury or even death.

#### **CAUTION**

This signal word indicates a potentially imminent danger that can result in minor to severe injuries.

#### **NOTICE**

This signal word indicates a potentially imminent danger which can result in damage to property.

#### **INFORMATION**

This signal word refers to practical application tips or particularly important information when using the LUB-S.

The design of the signal boxes is based on ANSI Z535.

## 1.2 Warning symbols

The following warning symbols are used in this user manual to alert you to hazards, prohibitions and important information:

		
<b>GENERAL WARNING SIGN</b>	<b>ELECTRICITY HAZARD</b>	<b>FLAMMABLE MATERIAL</b>



## 1.3 Structure of the safety instructions

The safety instructions in this user manual are structured according to the following system:

	<b>CAUTION</b>
	<p><b>The text explains the consequences of disregarding the reference.</b></p> <ul style="list-style-type: none"><li>• The text shows what to do as an instruction.</li></ul>

## 1.4 Symbols for information

The following information symbols are used in the text and instructions in this manual:

-  Requests you to take action
-  Shows the consequences of an action
-  Additional information about the action

## 2. Safety

All persons working with the LUB-S must follow these operating instructions, in particular the safety instructions and the rules and regulations applicable at the place of use. Generally applicable legal regulations and other rules as well as the relevant rules and regulations for accident prevention (e.g. Personal Protective Equipment (PPE)) and environmental protection must be observed.

### 2.1 EG/EU Directive

Within the scope of the EC/EU Directive, (re)commissioning of a machine on which the LUB-S has been installed and/or fitted is prohibited until it has been clearly established that the machine complies with the provisions of the applicable directive.

An EC/EU declaration of conformity for the LUB-S can be found in the appendix.

### 2.2 Hazards

In order to avoid danger to the user or damage to the machine on which the LUB-S is used, the LUB-S may only be used for its intended purpose and in a technically safe condition.

Always inform yourself about the general safety instructions before starting to work.

### 2.3 Staff

Only qualified staff who has read and understood this manual may work with the LUB-S. Local and/or company regulations apply accordingly.

## 2.4 Reasonably predictable misuse

Any use of the LUB-S which exceeds the maximum permissible technical data is generally considered to be improper and therefore prohibited.

## 2.5 Usage for the intended purpose

The following points must be observed for the intended purpose of using the LUB-S:

- The LUB-S is exclusively approved for industrial use.
- The LUB-S may be used exclusively in accordance with the technical data.
- Unauthorized structural alterations to the LUB-S are not permitted.
- Read the user manual and act accordingly.
- During operation of the LUB-S, a visual inspection of the LUB-S as well as of the lubrication point must be carried out regularly. Any anomalies must be eliminated immediately and the cause rectified.
- Refilling the cartridge is not permitted.
- The LUB-S may not be opened or disassembled.
- Only lubricants approved by the manufacturer may be used.
- Relevant regulations and rules on work safety, accident prevention and environmental protection must be observed.
- Work and activities with and on the LUB-S are only permitted with appropriate authorisation.

All other uses than the aforementioned intended usage or the disregard of one of the above points shall be deemed improper usage. In this case no liability and/or warranty is assumed.





## 2.6 Warranty and liability

If the following items are disregarded, all warranty and liability claims for personal injury and/or damage to property are excluded:

- Non-observance of the instructions for transport and storage;
- misuse;
- Improper or unperformed maintenance or repair work;
- Improper assembly / disassembly or improper operation;
- Operation of the LUB-S with defective protective devices and devices;
- Operation of the LUB-S without lubricant;
- Operation of the LUB-S with non-approved lubricant;
- Operation of heavily contaminated LUB-S;
- Modifications or alterations which may be carried out without the written permission of Gruetznner GmbH have taken place;
- Opening and/or partial or complete disassembly of the LUB-S.

## 2.7 General safety instructions

The following safety instructions are given for the LUB-S:

	<p style="text-align: center;"><b>DANGER</b></p> <p><b>Damaged or incorrect electrical connections or unauthorized live components lead to serious injuries or even death.</b></p> <ul style="list-style-type: none"> <li>• Have all electrical connection work carried out by qualified personnel only.</li> <li>• Replace damaged cables or plugs immediately.</li> </ul>
	<p style="text-align: center;"><b>NOTICE</b></p> <p><b>Loose or overloaded screw connections can cause damage to the LUB-S.</b></p> <ul style="list-style-type: none"> <li>• Mount and check all screw connections with the permissible torques specified for this purpose. Use a calibrated torque wrench.</li> </ul>
	<p style="text-align: center;"><b>WARNING</b></p> <p><b>Lubricants are flammable.</b></p> <ul style="list-style-type: none"> <li>• In case of fire, do not use a water jet to extinguish the fire.</li> <li>• In case of fire, use only suitable extinguishing agents such as powder, foam and carbon dioxide.</li> <li>• Observe the relevant safety instructions of the lubricant manufacturer on the safety data sheet of the lubricant used.</li> </ul>
	<p style="text-align: center;"><b>CAUTION</b></p> <p><b>Lubricants can cause skin irritations.</b></p> <ul style="list-style-type: none"> <li>• Avoid direct skin contact.</li> </ul>
	<p style="text-align: center;"><b>NOTICE</b></p> <p><b>Lubricants can contaminate soil and water.</b></p> <ul style="list-style-type: none"> <li>• Use and dispose lubricants properly.</li> </ul>

## 3. Description of function

### 3.1 General information

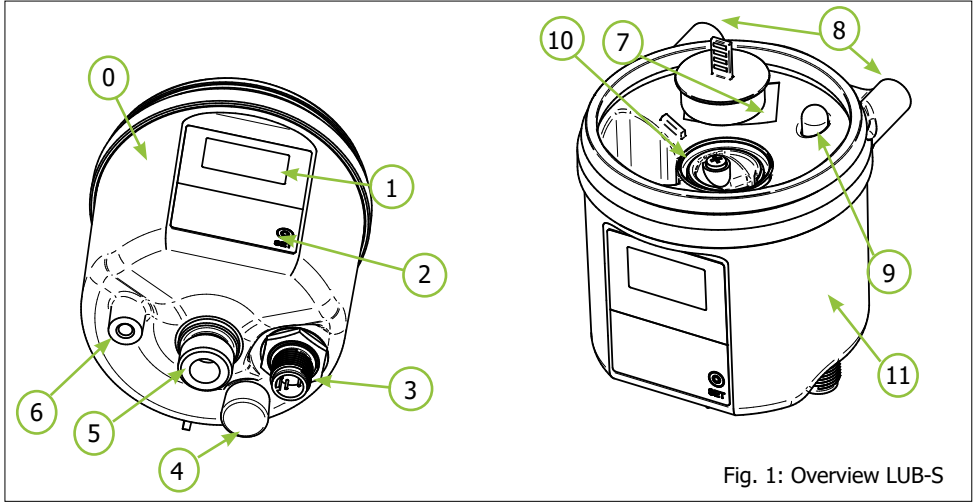

Fig. 1: Overview LUB-S

Nr.	Description
0	Lubricus-S (LUB-S)
1	OLED-Display
2	Action area (for actions with the activation and programming key)
3	M12x1 electrical interface
4	Activation and programming key
5	Lubricant outlet / M16 male thread for bottom mounting
6	M5 female thread for bottom mounting
7	Serial number of the LUB-S
8	M5 female thread for rear mounting
9	Cartridge sensor
10	Lubricant inlet with thread for cartridge
11	Nameplate with designation and CE mark

The LUB-S is designed as an extremely compact piston pump for the lubricant grease. The outlet is secured by an integrated check valve. Approx. 0.15 ml of lubricant is delivered with each lubrication stroke; several lubrication strokes in succession can be set. The various operating states are shown in the front-mounted display; further information (empty level warning, empty cartridge level, errors) can be accessed.

The present LUB-S as 24V DC version has an electrical interface. The supplied activation and programming key can be used to adjust or set the operating mode and the quantity of lubricant delivered per time in order to supply the lubrication point with the ideal quantity of lubricant.

## 3.2 Nameplate and designation

The nameplate of the LUB-S is visibly attached to the side of the pump itself. There the CE mark and the serial number of the LUB-S are visible. Refer to Fig. 1 for the location of the nameplate and serial number.

## 3.3 Scope of delivery

The scope of delivery includes the LUB-S and any accessories ordered. The LUB-S is delivered without lubricant cartridge.

All versions of the LUB-S are prefilled with a neutral, food-grade (H1) lubricant (approx. 3 ml), which can be mixed with the lubricants approved by Gruetzner GmbH, to simplify the initial commissioning. The manufacturer's designation is Total Ceran FG. Further data and documentation on the lubricant Total Ceran FG are available on request from Gruetzner GmbH.

### 3.4 Technical data

Housing			
<b>Dimensions without cartridge</b>	83 x 82 x 85 (W x H x D)		
<b>Dimensions with 125 ml cartridge</b>	83 x 149 x 85 (W x H x D)		mm
<b>Dimensions with 250 ml cartridge</b>	83 x 185 x 85 (W x H x D)		
<b>Weight (without cartridge) approx.</b>	350		g
<b>Mounting options</b>	Back: female thread M5 (2x) Bottom: female thread M5 (1x) Bottom: male thread M6x1,5 (1x)		
<b>Preferred mounting position</b>	upright		
<b>Material housing</b>	PA 6.6 GF30 / POM		
<b>Material outlet</b>	stainless steel		
<b>Operating temperature</b>	- 20 ... + 70		°C
Lubricant and hydraulics			
<b>Volume cartridge</b>	125 / 250		ml
<b>Lubricant characteristics</b>	Grease until NLGI class 2		
<b>Number of outlets</b>	1		
<b>Hydraulic connection</b>	via PA-tube Ø 6mm directly (with adapter)		
<b>Number of lubrication points</b>	depending on accessories		
<b>Max. pressure build-up</b>	50		bar
<b>Lubricating volume</b>	<b>per stroke</b>	0,15	ml
Electrics			
<b>Display</b>	OLED-Display		
<b>Operating voltage</b>	24 (+/- 5%)		V DC
<b>Protection</b>	0,75 (träge)		A
<b>Protection class</b>	IP 54		
<b>Current consumption</b>	$I_{\max} < 0,3$	$I_{\text{qiescent}} < 0,025$	A

## 4. Transport and storage

### 4.1 Packaging

The LUB-S is delivered in an outer packaging (cardboard box) and - depending on the scope of delivery with a lubricant cartridge and other accessories - in the same package. To protect them from moisture and dirt, they are also packed in PE films.

Dispose the packaging materials at the designated disposal points in compliance with the relevant national and company regulations.

After receiving the LUB-S, check the delivery note for completeness and correctness. Any missing parts or damage must be reported immediately to the forwarding agent, the insurance company or Gruetzner GmbH in writing.

### 4.2 Transport

	<b>NOTICE</b>
	<p><b>Hard shocks, e.g. due to falling or setting down too hard, can damage the LUB-S.</b></p> <ul style="list-style-type: none"><li>• Do not throw the LUB-S.</li><li>• When using lifting equipment, only use hoists and load handling attachments in perfect condition and with sufficient load capacity.</li><li>• The permissible lifting weight of the lifting device must not be exceeded.</li></ul>

### 4.3 Storage

Store the LUB-S in its original packaging in a vertical position in a dry, frost-free environment at an ambient temperature of - 20°C to + 40°C. The maximum storage time in unopened condition is 2 years.

The so-called „First-In-First-Out-Principle“ (FIFO) is recommended for storage logistics.

## 5. Mounting

### 5.1 Preparations

Before starting to work, inform yourself in detail about the LUB-S using this user manual; in particular about the general safety instructions (section 2.7). Prepare the installation site carefully.



#### NOTE

**Pressurised air can damage the seals of the LUB-S and can transport dirt and foreign matter into the LUB-S or the lubricant.**

- Do not use pressurised air.
- Make sure that there is no coarse dirt in the mounting area.

### 5.2 Mechanical mounting

Three brass inserts with internal threads on the housing and an M16x1.5 external thread on the lubricant outlet are available for fastening the LUB-S at the intended mounting location.

- ▶ Fasten the LUB-S using a minimum of two DIN 912 socket head screws of size M5x8 (screw-in depth on the LUB-S > 6mm) or longer on the housing or with an M16x1.5 nut on the lubricant outlet.
- ▶ Secure the screws or nuts with suitable thread-locker.

ⓘ Suitable adapters, brackets and plates are also available as accessories for mounting.

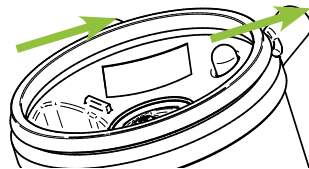
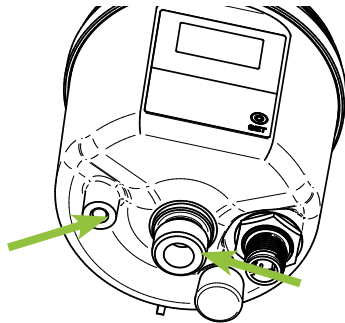

### 5.3 Mounting height

When selecting the mounting location, observe the minimum mounting heights required for the LUB-S in the version with 125 ml cartridge volume or 250 ml cartridge volume for disassembly and assembly of the cartridge.

**min. mounting height version  
125 ml [mm]**

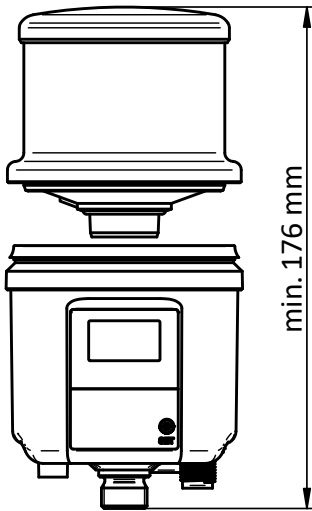

**min. mounting height ver-  
sion 250 ml [mm]**

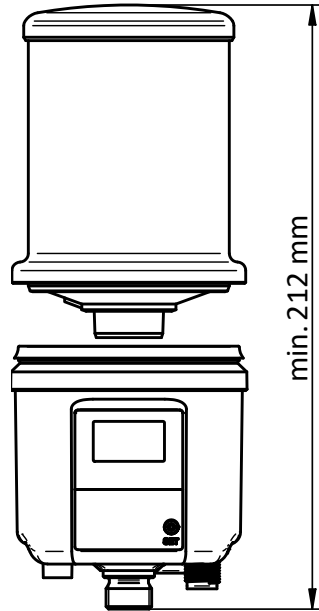

## 5.4 Mounting of the LUB-S

1. Remove the protective cap from the top of the LUB-S.

- ▶ Remove the yellow protective cap from the top of the lubricant inlet of the LUB-S.
- ▶ Dispose of the protective cap properly.

ⓘ Make sure that no dirt, water or foreign bodies enter/s the lubricant inlet.

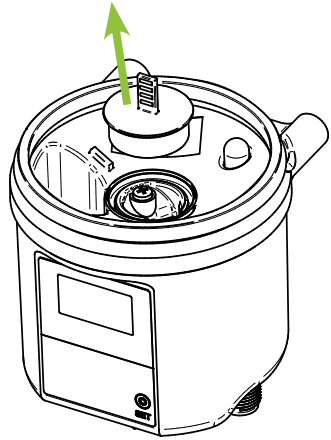

2. Mounting the lubricant cartridge

- ▶ Turn the cap on the lubricant cartridge counterclockwise and pull it off.
- ▶ Place the full lubricant cartridge on the LUB-S with the label facing forwards.
- ▶ Turn the lubricant cartridge clockwise until it physically stops on the LUB-S.

ⓘ The end position should be reached after two full rotations when the lubricant cartridge label is aligned with the front of the LUB-S.

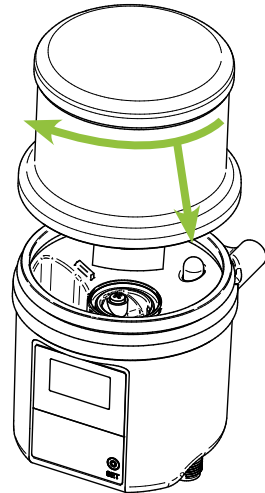

3. Remove the protective caps from the bottom of the LUB-S.

- ▶ Unscrew the yellow protective cap counterclockwise from the bottom of the lubricant outlet of the LUB-S.
- ▶ Pull the black protective cap off the M12x1 electrical interface at the bottom in the direction of the arrow.



4. Connect the electrical interface

- ▶ Connect the LUB-S to the external power supply or controller via the M12x1 interface on the side of the LUB-S using a suitable connecting cable.

ⓘ Depending on the application, both connection cables with straight or angled socket can be used.

ⓘ Please refer to chapter 7.1 or chapter 8.1 for the condition of the connection cable.

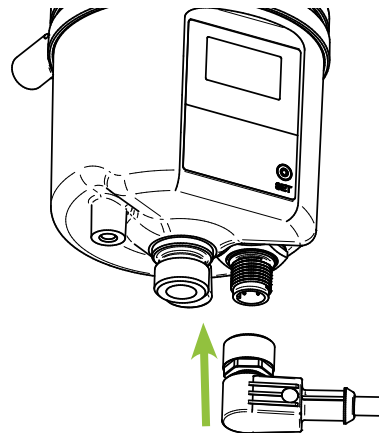

**DANGER**

**Defective or faulty electrical connections or unauthorized live components can lead to serious injuries or even death.**

- Have all electrical connection work carried out by qualified personnel only.
- Replace damaged cables or plugs immediately.
- Before carrying out any electrical installation work, observe the five safety rules of electrical engineering:
  - Unlocking
  - Secure against unintentional restarting.
  - Check that there is no voltage.
  - Ground and short-circuit.
  - Cover adjacent live parts.

## 5.5 Start-up

Mount the LUB-S carefully according to the steps described in the chapters before. Depending on the scope of delivery, you must also carry out the following additional measures for the first-time commissioning:

### 1. Check the assembly

Make sure that the LUB-S is properly and completely assembled. In particular, the battery must be inserted and a lubricant cartridge must be fitted.

### 2. Power on

If you want to put the LUB-S into operation, switch on the LUB-S. Only if you switch the LUB-S on, it delivers lubricant to the lubrication point according to the settings. The detailed description for powering on can be found in chapter 6.3.1.

### 3. Setting the cartridge size

The LUB-S is factory-set to use cartridges with a 125 cm<sup>3</sup> capacity. If you use a cartridge with a 125 cm<sup>3</sup> capacity during operation, you can skip this step. If you use a cartridge with a capacity of 250 cm<sup>3</sup>, you must adjust this in the software of the LUB-S in the Settings menu, see Chapter 6.3.4.

### 4. Hydraulic connection

Connect the consumer hydraulically to the LUB-S. If you connect tubes to the LUB-S, make sure, that the tubes and connectors are installed tightly, cleanly and correctly.

① Ideally, use tubes prefilled with the appropriate lubricant!

### 5. Activate filling function

Execute the filling function. The detailed description can be found in chapter 6.3.5. The LUB-S carries out a pump cycle PZ with a total of 40 lubrication strokes C with the activation.

### 6. Check the settings on the LUB-S

Compare the basic settings of the LUB-S with the values required for the lubrication point and adjust them if necessary. Changes to the LUB-S must be made in the Settings menu, see Chap. 6.3.4.

## 6. Operation and settings

### 6.1 General information

The following two graphics show an overview of the most important terms necessary for programming and understanding the LUB-S (example of an LUB-S with 250 ml cartridge; The parameter C is here 2):

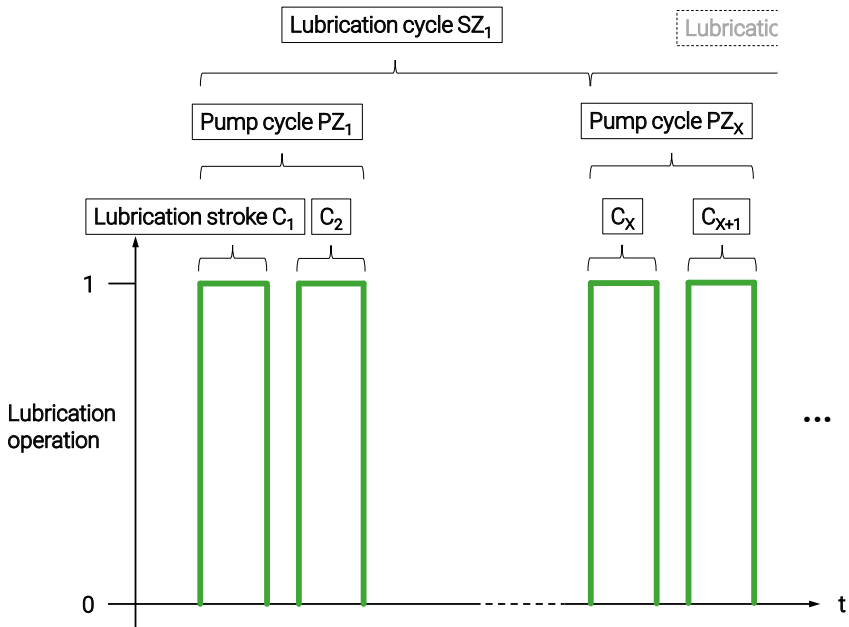

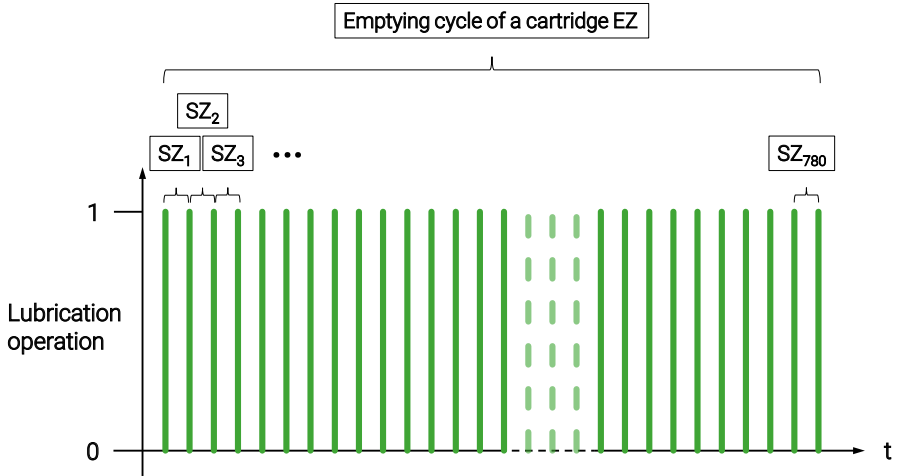

What you should know about operating and setting the LUB-S:

✓ The LUB-S is designed as a single-point lubricator for one lubrication point. Depending on the specific application, the LUB-S can also supply lubricant reliably and cleanly to a limited number of lubrication points. For this purpose, parts of the system accessories from the manufacturer (e.g. progressive distributor) must be connected to the LUB-S. If necessary, changes must be made to the settings on the LUB-S to ensure safe and reliable operation

✓ Die LUB-S ist ein zyklengesteuerter Schmierstoffgeber, welcher über die integrierte Mikroelektronik zeitbasiert arbeitet und an eine 24 V DC Spannungsversorgung angeschlossen wird. Die LUB-S fördert dabei zyklisch eine definierte Menge Schmierstoff aus der Kartusche an den Auslass. Es kann zwischen drei Betriebsmodi gewählt werden:

- The **operating mode „Setting lubrication cycle duration“** allows setting the number of lubrication strokes (C) and a lubrication cycle duration (h) in hours. Lubrication cycle durations (h) can be set between 1...240 hour(s) and lubrication strokes (C) between 1...10.

- The **operating mode „Setting emptying cycle time“** allows the cartridge emptying time to be set in months. Emptying times between 1...24 month(s) can be set. The pump automatically calculates the lubrication cycle time.

- Alternatively, the LUB-S can also be integrated into a control system (PLC) and commanded and controlled via this in **„Pulse control mode“**.

✓ A lubrication cycle SZ consists of one (1) pump cycle PZ and a pause time  $t_p$ . The pumping cycle PZ can consist of a minimum of one (1) and a maximum of ten (10) lubricating strokes C. The up to ten (10) lubrication strokes C are performed directly one after the other. After the end of the pump cycle PZ, the LUB-S pauses until the pause time  $t_p$  has elapsed and automatically executes the next lubrication cycle SZ after the set lubrication cycle duration  $t_{SZ}$  has elapsed.

✓ The disposable interchangeable cartridge with 125ml or 250ml lubricant guarantees a controlled and constant quality of the lubricant and is filled without air bubble inclusions. The LUB-S allows a high supply security of the lubrication point and prevents failures. The LUB-S in its present version is designed for the lubricant grease.

✓ The LUB-S cannot be used in the present version without a lubricant cartridge. Depending on the version ordered the cartridge can already be included in the scope of delivery and may already be connected and installed in the LUB-S.

✓ If you have any questions about your application and the correct settings for the LUB-S, please contact the manufacturer.

The LUB-S is always delivered ex works with the following settings:

<b>Operation mode</b>	Setting lubrication cycle duration
<b>Cartridge size</b>	125 ml
<b>Mode</b>	OFF (LUB-S is switched off)

ⓘ The factory settings foresee using the LUB-S in the operation mode **„Setting lubrication cycle duration“**. If you want to operate the LUB-S in the **„Pulse control mode“** via external control (PLC) or in the operation mode **„Setting emptying cycle time“**, you have to make changes in the Settings menu of the LUB-S, see chapter 6.3.4.

ⓘ It is essential to ensure that the cartridge size used matches the cartridge size set in the Settings menu.

## 6.2 Menu and display messages

The display of the LUB-S can be used both to read information visually and, in conjunction with the activation and programming key attached on the bottom of the LUB-S, to change settings or trigger individual actions.

In principle, settings can be changed or actions triggered both when the LUB-S is switched off (OFF) and when it is switched on (ON).

The individual submenus are presented, described and explained in detail in Chap. 6.3.1 to 6.3.5. The symbolic representations used below are described as follows:

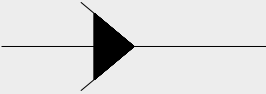
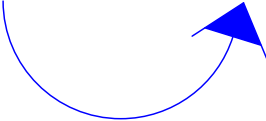
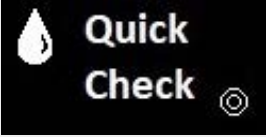
Symbol	Description	Note
	OLED display	In the OLED display, indications and information are shown visually both in operation and for programming
	Sequence arrow	The black sequence arrow indicates the unchangeable basic structure of the menu.
	Action arrow	The blue action arrow shows the sequence of touching the action area with the activation and programming key once.
	Sub-menu	In the respective submenus information can be read, dispensing processes can be initiated and settings can be changed.

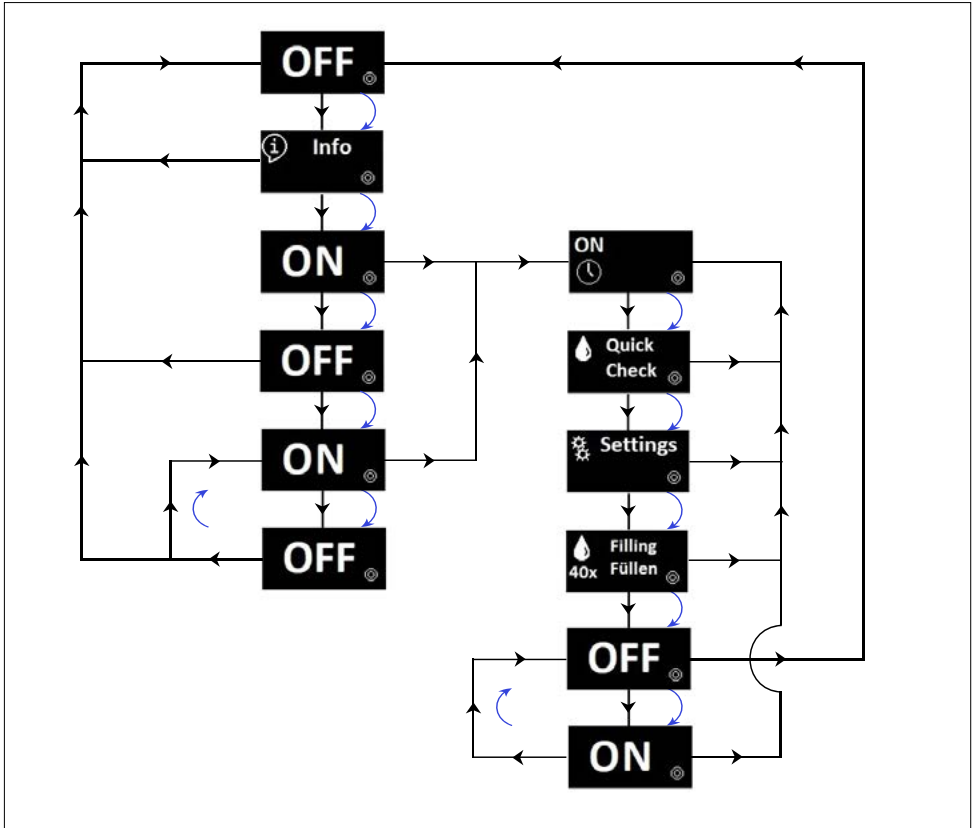

The graphic above illustrates the unchangeable basic flowchart of the LUB-S menu navigation as well as the options for branching to the Sub-menus. The illustration for the operating mode „Setting lubrication cycle duration“ was selected as an example.

① The LUB-S can be switched on and off at several points in the menu navigation. For details see chapter 6.3.1.

① The Info-menu can only be accessed from the OFF mode (LUB-S is switched off). The Info-menu provides you with an informative overview of the current LUB-S settings. For details see chapter 6.3.2.

① The Quick-Check-menu can only be accessed from the ON mode (LUB-S is switched on). The Quick-Check-menu allows you to manually trigger a pump cycle on the LUB-S. For details see chap. 6.3.3.

① The Settings-menu can only be accessed from the ON mode (LUB-S is switched on). The Settings-menu allows you to make changes to the operating mode and to set the size of the cartridge used. For details, see Chapter 6.3.4. In addition, the Settings-menu allows you to make changes to the settings within the different operating modes - and thus to the dispensing behavior - of the LUB-S. For details, see Chap. 6.3.4.1, 6.3.4.2 or 6.3.4.3.

① The Filling-menu can only be accessed from the ON mode (LUB-S is switched on). The LUB-S thus carries out a pump cycle PZ with a total of 40 lubrication strokes C with the activation. The detailed description of this can be found in Chap. 6.3.5.

For visual output, information on the various states of the LUB-S is shown on the display. The following table illustrates the indications on the display as well as the explanation of the respective output:

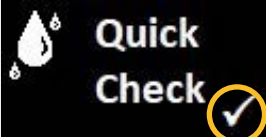
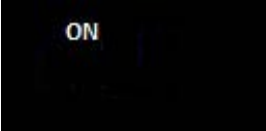
Display	Description	Naming
	The double circle in the lower right corner is displayed when the action area is touched with the activation and programming key (activation and programming key detected).	Activation and programming key detected by LUB-S
	The confirmation hook in the lower right corner is displayed when an entry has been confirmed. In addition, the display flashes twice.	Acceptance of changed value
	In the ON and OFF state, the screen saver is activated after 10 seconds. ON and OFF are shown in reduced size on the display.	Screen saver

## 6.3 Actions with the activation and programming key

The activation and programming key attached to the underside of the LUB-S allows you to perform actions and changes in the settings of the LUB-S. This activation and programming key can be easily and permanently stored on the LUB-S.

1. Remove the action and programming key.

▶ Remove the activation and programming key from the underside of the LUB-S.

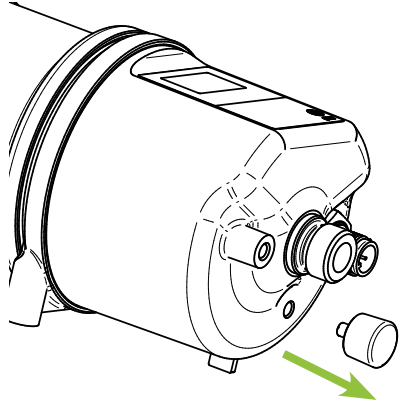

ⓘ The activation and programming key is permanently held magnetically in the hole on the underside of the LUB-S.

2. Guide the activation and programming key to the action area.

▶ Place the activation and programming key on the action area on the front of the LUB-S.

➡ As soon as the activation and programming key on the action area has been detected by the LUB-S, the double circle in the display lights up. The menu runs in a rhythm of approx. 2 seconds.

▶ Remove the activation and programming key from the action area as long as the desired menu item is shown in the display.

➡ The double circle disappears. You have performed an operation. The display flashes twice together with the confirmation hook.

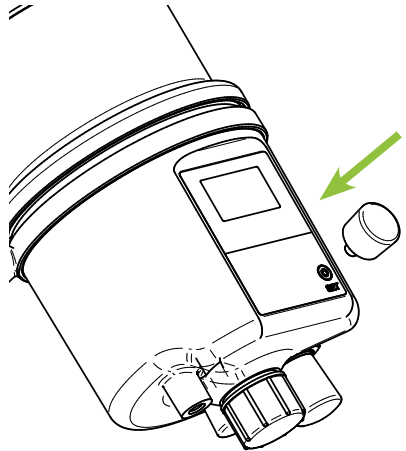

► At the end of the operation or change of settings, insert the activation and programming key again into the hole provided on the underside of the LUB-S.

ⓘ Please note, however, that in the event of faults or changes to be made, no changes or actions can be carried out on the LUB-S without the activation and programming key. The activation and programming key must be remounted in the housing of the LUB-S after actions have been performed. If you want to protect LUB-S against unintentional modification or manipulation, you can also store the activation and programming key in another location.

## 6.3.1 Switching LUB-S on and off

Switch the LUB-S on:

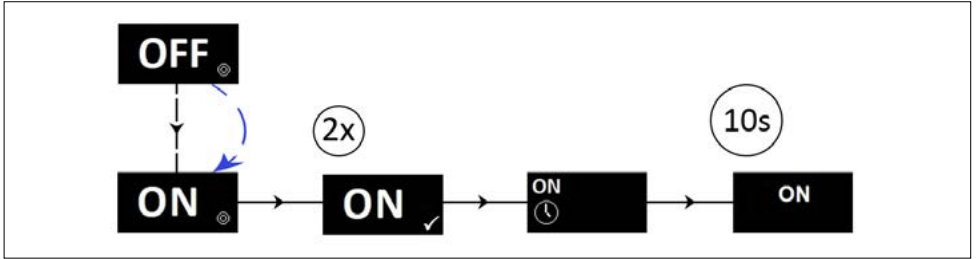

✓ LUB-S is switched off (OFF).

▶ Hold the activation and programming key on the action area. The double circle appears in the bottom right corner. Leave the activation and programming key on the action area until **ON** appears in the display. Remove the activation and programming key from the action area as long as **ON** is shown in the display. The double circle disappears; the confirmation hook appears; the display and the hook flash twice for visual confirmation.

⇒ After the self-check of the LUB-S, **ON** is shown in the display. In this state, the LUB-S has been successfully commissioned and will supply lubricant according to the set values. The LUB-S activates a screen saver after approx. 10 seconds. The **ON** indicator on the display moves from left to right and from top to bottom.

▶ Insert the activation and programming key into the hole provided on the underside of the LUB-S.

When switched on, the LUB-S shows you the currently set operating mode. The following displays represent the individual operating modes:

### Setting lubrication cycle duration



Setting of **pause time**  
(1 to 240 hours)  
and **strokes per cycle**  
(1 to 10 strokes)

### Setting emptying time



Setting of **emptying time**  
(1 to 24 months)

### Pulse control mode



Control via  
PLC / machine control

## Switch the LUB-S off:

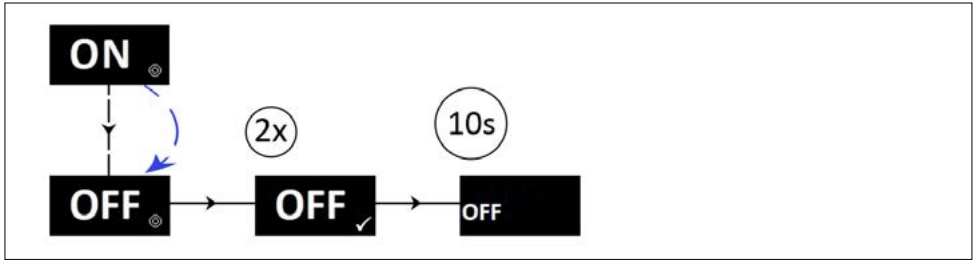

✓ LUB-S is switched on (ON).

▶ Hold the activation and programming key on the action area. The double circle appears in the bottom right corner. Leave the activation and programming key on the action area until **OFF** appears in the display. Remove the activation and programming key from the action area as long as ON is shown in the display. The double circle disappears; the confirmation hook appears; the display and the hook flash twice for visual confirmation.

➡ LUB-S is switched off (OFF); OFF appears in the display. The LUB-S no longer dispenses lubricant. The LUB-S activates a screen saver after approx. 10 seconds. The OFF indicator on the display moves from left to right and from top to bottom.

▶ Insert the activation and programming key into the hole provided on the underside of the LUB-S.

ⓘ The LUB-S can be switched off in any state in the manner described here.

## 6.3.2 Get information about the LUB-S

The Info menu is used to inform the user about the firmware used in the LUB-S and the settings made and currently active.



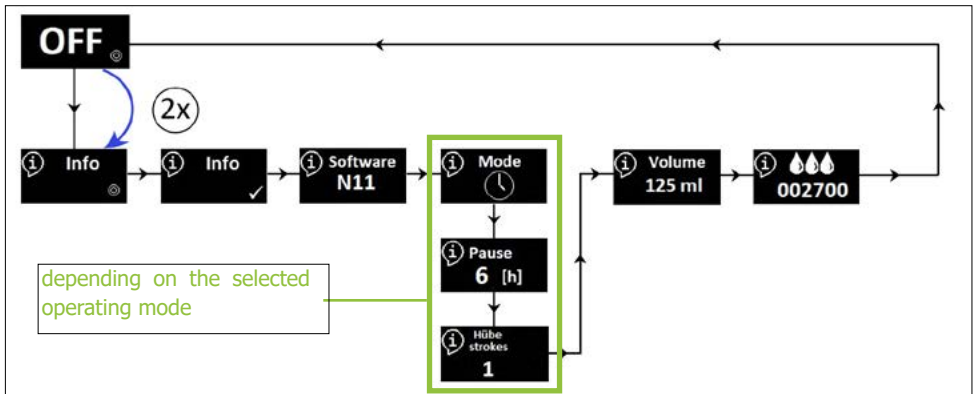











Nothing can be changed by the user in the Info menu. The values of the set parameters are displayed in an unchangeable sequence. The values displayed depend on the selected operating mode. The following shows the basic sequence for the set operating mode Setting lubrication cycle duration.



### Procedure:

- ✓ LUB-S is switched off (OFF).
- ▶ Remove the activation and programming key from the underside of the LUB-S and place it on the action area.
- ▶ Hold the activation and programming key on the action area. The double circle appears in the bottom right corner. Leave the activation and programming key on the action surface until **Info** appears in the display. Remove the activation and programming key from the action area until Info appears in the display. The double circle disappears; the confirmation hook appears; the display and the hook flash twice for visual confirmation.
- ➡ LUB-S informs you optically on the display about the set values.
- Insert the activation and programming key into the hole provided on the underside of the LUB-S.

ⓘ The Info menu can only be accessed from OFF mode (LUB-S switched off). If you have accessed the Info menu, you will automatically return to the OFF mode.

Display text	Explanation
<b>General information regardless of the selected operating mode</b>	
 Software N11	Alphanumeric identifier of the firmware of the LUB-S
 Mode 	Selected operating mode (factory settings see chap. 6.1)
 Volume 125 ml	Set value of the <b>cartridge size</b>
  002700	Number of completed lubrication strokes C
<b>Specific displays in the operating mode Setting lubrication cycle duration</b>	
 Mode 	Selected operating mode <b>Setting lubrication cycle duration</b>
 Pause 6 [h]	Set value of the variable <b>lubrication cycle duration</b> in hours (1 to 240 hours)
 Hübe strokes 1	Set value of the variable <b>lubrication strokes C</b> per pump cycle (1 to 10 cycles)
<b>Specific displays in the operating mode setting emptying time</b>	
 Mode 	Selected operating mode <b>Setting emptying time</b>
 Monate months 1	set value of the variable <b>emptying time</b> of the cartridge in months (1 to 24 months)
<b>Specific displays in operating mode pulse control</b>	
 Mode 	Selected operating mode <b>pulse control</b>

## 6.3.3 Perform a Quick-Check

The Quick-Check is used to activate the LUB-S by hand. In this way, a pump cycle PZ can be triggered directly at the LUB-S. This function can be used, for example, to manually check the condition of the lubrication point.

After the Quick-Check has been triggered, the LUB-S carries out a pump cycle PZ; the number of lubrication strokes carried out per outlet is exactly as set in the variable Number of lubrication strokes per lubrication cycle C in the Settings menu. During the lubrication strokes C, the counterpressure per outlet measured by the integrated microelectronics is shown in the display as an approximate value in the unit bar. After a completed lubrication stroke, the approximate maximum counterpressure reached during the lubrication stroke is shown in bar on the display per outlet.

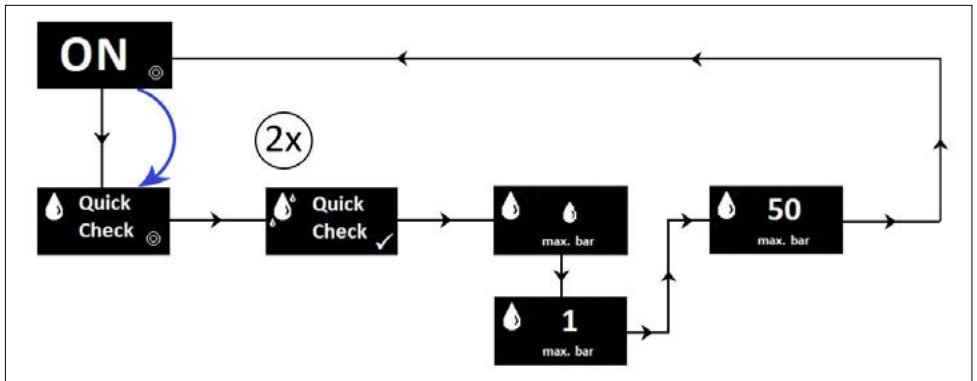

### Procedure:

- ✓ The LUB-S is switched on and there is no fault or error.
  - ▶ Remove the activation and programming key from the underside of the LUB-S and place it on the action area.
  - ▶ Hold the activation and programming key on the action area. The double circle appears in the bottom right corner. Leave the activation and programming key on the action area until **Quick-Check** appears in the display. Remove the activation and programming key from the action area until Quick-Check appears in the display. The double circle disappears.
  - ⊕ The confirmation hook appears; the display and the hook flash twice for visual confirmation. The LUB-S starts the pump cycle PZ.
  - ▶ Reattach the activation and programming key in the opening provided on the underside of the LUB-S.
  - ▶ Observe the back pressure values displayed on the display if they are of interest to you.
- ⓘ During the pump cycle, the display shows the back pressure of the current lubrication stroke depending on the outlet.

► If you want to cancel the operation: Move the activation and programming key to the action area during a lubrication stroke and wait until the STOP symbol appears in the display. Remove the activation and programming key from the action surface as long as STOP is shown in the display. The double circle disappears.

- ⓘ The confirmation hook appears; the display and the hook flash twice for visual confirmation.
- ⓘ The LUB-S cancels the Quick-Check. In addition, the number of complete lubrication cycles is shown in the display.

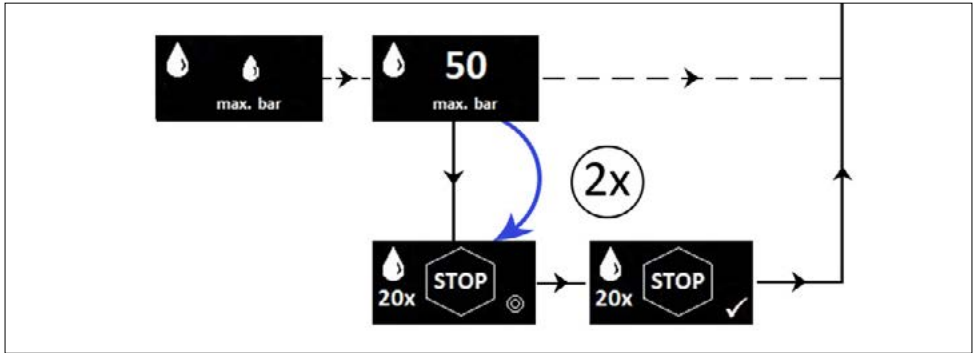

- ⓘ If you use the Quick-Check in the operating mode Setting emptying time, this has a slightly shortening effect on the set emptying time.
- ⓘ The Quick-Check can only be started from ON mode (LUB-S switched on). After you have activated the Quick-Check, you will automatically return to ON mode.
- ⓘ The quick check can only be started on the display in the operating modes Setting lubrication cycle duration and Setting emptying time. In the operating mode Pulse control, the quick check must be triggered by the PLC.

## 6.3.4 Set operating mode and cartridge size

The Settings menu allows changing general parameters of the LUB-S setting as well as changing specific parameters of the selected operating mode. The general parameters include adjusting the operating mode and changing the cartridge size of the LUB-S used. You can switch between the operating modes **Setting Lubrication Cycle Duration**, **Setting Emptying Time** and **Pulse Control mode**. This chapter explains how to select the operating mode and change the cartridge size between 125 ml and 250 ml. The explanation of how to change specific parameters within the different operating modes and their explanation is given in the following chapters.

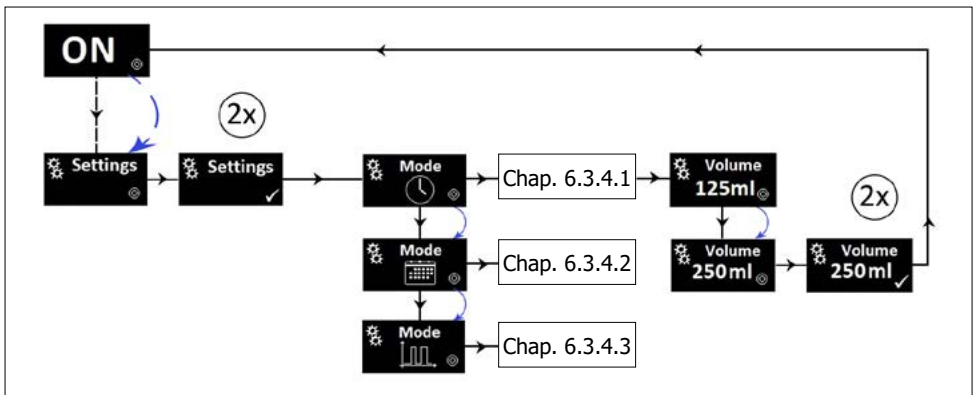



### Procedure:

- ✓ The LUB-S is switched on and there is no fault or error.
- ▶ Remove the activation and programming key from the underside of the LUB-S and place it on the action area.
- ▶ Hold the activation and programming key on the action area. The double circle appears in the bottom right corner. Leave the activation and programming key on the action area until Settings appears in the display. Remove the activation and programming key from the action area until Settings appears in the display. The double circle disappears.
- ⊙ The confirmation hook appears; the display and the hook flash twice for visual confirmation.

## Changing the operating mode:

As soon as the Mode display appears, the active operating mode is displayed. The following operating modes are available for the LUB-S:

Display	Operating mode	Explanation
	Setting Lubrication cycle duration (Dial symbol)	In the operating mode „Setting lubrication cycle duration“ you can set the lubrication cycle duration in hours between two lubrication cycles and additionally the number of lubrication strokes per pump cycle.
	Setting Emptying time (Calendar icon)	In the operating mode „Setting emptying time“ you can set the emptying time in months (=running time).
	Pulse control mode (Control pulse symbol)	In the operating mode „Pulse control“ you can only trigger lubrication strokes on the LUB-S with the help of an external control or PLC and certain signals.

- ▶ If you want to change the operating mode, move the activation and programming key back to the action area as soon as the **Settings** display appears in conjunction with one of the symbols.
  - ⇒ The double circle appears and the next operating mode is shown in the display. The double circle lights up for as long as the activation and programming key is on the action surface; the adjustable operating modes run through alternately.
  - ▶ When the desired operating mode is shown in the display, remove the activation and programming key from the action area.
    - ⇒ The double circle disappears and the confirmation hook appears; for visual confirmation, the display and the hook flash twice. The selected operating mode has now been accepted and is active. If necessary, adjust the settings within the operating mode, see Chap. 6.3.4.1, Chap. 6.3.4.2 and Chap. 6.3.4.3.

## **No changing of the operating mode:**

- ▶ If you do not want to change the operating mode, the activation and programming key must remain removed from the action area.
- ↻ The confirmation hook appears; for visual confirmation, the display and the hook flash twice. The submenu now automatically takes you to the specific parameters within the operating mode. The explanation of the parameters and the setting options can be found in the following chapters.

If the specific parameters of the operating modes have been run through without any changes, the cartridge volume appears as the last setting option with the display keyword Volume. You now have the option of changing the value of the cartridge size.

## **Change the value of the cartridge size:**

- ▶ If you want to change the cartridge size, move the activation and programming key back to the action area.
- ↻ The double circle appears and the next cartridge size is shown in the display. The double circle lights up as long as the activation and programming key is on the action surface; the adjustable cartridge sizes run through alternately one after the other.
- ▶ When the desired cartridge size is shown in the display, remove the activation and programming key from the action area.
- ↻ The double circle disappears and the confirmation hook appears; for visual confirmation, the display and the hook flash twice. The selected cartridge size has now been accepted.

## **No changing the value of the cartridge size:**

- ▶ If you do not want to change the cartridge size, the activation and programming key must remain removed from the action area.
  - ↻ ↻ The confirmation hook appears; the display and the hook flash twice for visual confirmation.
- ⓘ The Settings menu can only be accessed from ON mode (LUB-S switched on). Once you have entered the Settings menu, you will automatically return to the ON mode.
- ⓘ Before commissioning, check if the correct cartridge size is set in the LUB-S software. The cartridge size used and the cartridge size set in the software must be identical!

### 6.3.4.1 Operating mode Setting Lubrication cycle duration

**General information:**

Term/Parameter	Shortcut	Value
Number of lubrication strokes per pump cycle	C	adjustable, 1 ... 10
Lubrication stroke time	$t_C$	predefined, 7s ... 17s
Relaxation time	$t_E$	predefined, 2s
Pause time	$t_P$	calculable
Pump cycle	PZ	–
Pump cycle duration	$t_{PZ}$	calculable
Lubrication cycle	SZ	–
Lubrication cycle duration	$t_{SZ}$	adjustable, 1h ... 240h
Emptying time	EZ	–
Emptying time of a cartridge	$t_{EZ}$	calculable

The different parameters can be calculated as follows:

$$t_{PZ} = C * t_C + (C - 1) * t_E$$

$$t_P = t_{SZ} - t_{PZ}$$

Simplified calculation of the **emptying time**  $t_{EZ}$  [h] depending on the selected cartridge:

	125 mL cartridge	250 ml cartridge
LUB-S	$= t_{SZ} * \frac{780}{C}$	$= t_{SZ} * \frac{1560}{C}$

The following graphic explains the parameters and terms in the operating mode Lubrication cycle time setting. The graphic shows the example of an LUB-S with 250 ml cartridge; the parameter C is 2.

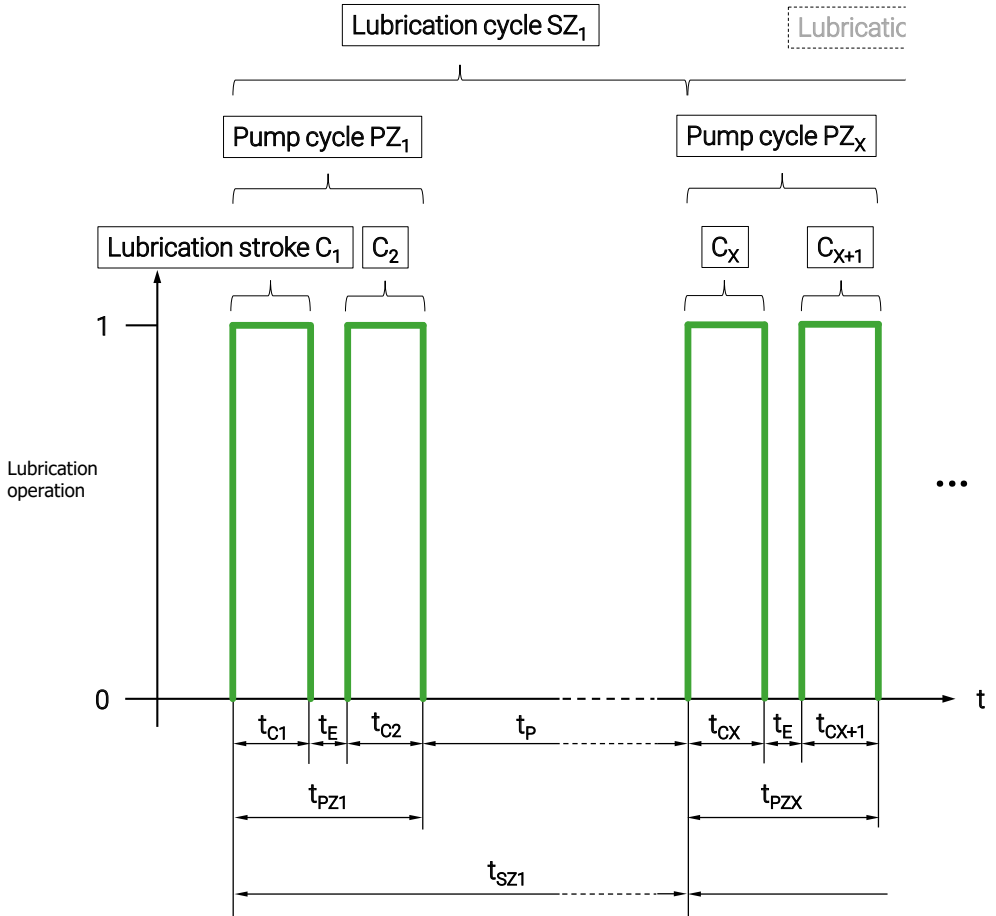

The following graphic explains the parameters and terms. The graphic shows the example of a LUB-S with two outlets. The parameter C is 1.

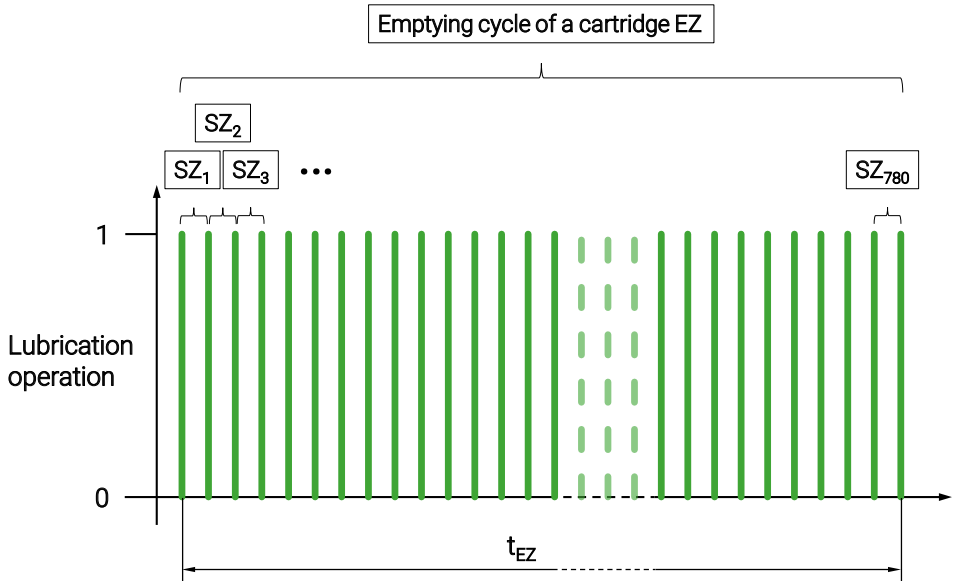

### Default settings Operating mode Setting Lubrication cycle duration:

Lubrication cycle duration	$t_{sz} = 6\text{h}$	The lubrication cycle duration is 6 hours.
Number of lubrication strokes	$C = 1$	The number of lubrication strokes is one (1) per outlet and per pump cycle.

ⓘ The default settings result in an emptying time (service life) for a full lubricant cartridge with a content of 125 ml of approx. 195 days (= approx. 6,4 months) provided that the LUB-S is permanently switched on and no extraordinary lubrication strokes have been carried out, e.g. by the filling or Quick-Check menu. In this case, a pump cycle is triggered by the LUB-S at the beginning of the set lubrication cycle duration of 6 hours. The emptying time depends on the selected cartridge size.

► Determine whether the default settings apply to your application and whether the lubrication point is supplied with the correct amount of lubricant per time unit.

If this is the case, you can operate the LUB-S in the operating mode Setting lubrication cycle duration with the basic settings.

If this is **not** the case, change the values for the lubrication cycle duration  $t_{sz}$  and/or the number of lubrication strokes  $C$  accordingly. This chapter explains how to make these changes.

ⓘ To use the LUB-S, it must first be properly mounted and installed and then switched on. Mounting is very simple and described in detail in Chap. 5; switching on is described in Chap. 6.3.1.

Definitions of the adjustable parameters for the lubrication cycle duration  $t_{sz}$  and the number of lubrication strokes  $C$  per pump cycle PZ and their respective permissible values:

$t_{sz} :=$  **lubrication cycle duration** in hours (h).  
The lubrication cycle duration can be set between 1 | 2 | 3 | ... | 240 hours.

$C :=$  **number of lubrication strokes** during a pump cycle PZ.  
The number of cycles  $c$  can be set between 1 | 2 | 3 | ... | 10 strokes.

## Performing changes:

The Settings menu allows changing specific parameters of the selected operating mode. This chapter explains the parameters essential for the operating mode Setting lubrication cycle duration and how you can change the specific parameters Lubrication cycle duration  $t_{sz}$  in hours and the number of lubrication strokes C per pump cycle PZ when the operating mode Setting lubrication cycle duration is selected.

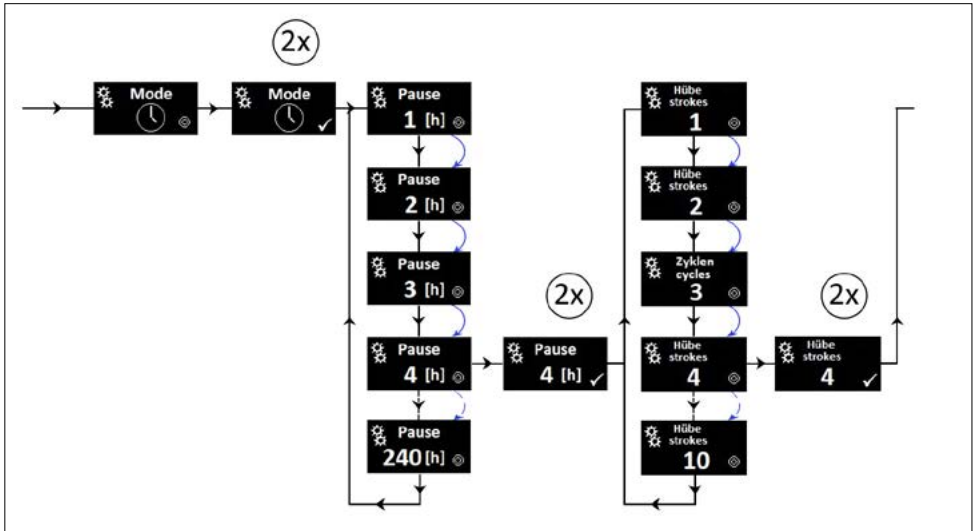

### Procedure:

- ✓ The LUB-S is switched on and there is no fault or error.
- ▶ Remove the activation and programming key from the underside of the LUB-S and place it on the action area.
- ▶ Hold the activation and programming key on the action area. The double circle appears in the bottom right corner. Leave the activation and programming key on the action area until **Settings** appears in the display. Remove the activation and programming key from the action area until Settings appears in the display. The double circle disappears.
- ⊖ The confirmation hook appears; the display and the hook flash twice for visual confirmation.

## Changing the lubrication cycle duration $t_{sz}$ :

As soon as the Settings menu has been selected, the active operating mode is displayed. To be able to set the lubrication cycle duration  $t_{sz}$ , the operating mode Lubrication cycle duration setting must be selected with the symbol of the dial. If this is not the case, change the operating mode accordingly. An explanation of how to change the operating mode can be found in Chap. 6.3.4.

After the operating mode Setting lubrication cycle duration is displayed, the lubrication cycle duration  $t_{sz}$  and then the number of lubrication strokes C can be set; direct access to the number of lubrication strokes C is not possible.

- In addition to the display of the active operating mode, the confirmation hook appears; the display and the hook flash twice for visual confirmation.
- In the next step, the currently set value of the lubrication cycle duration ( $t_{sz \text{ actual}}$ ) is shown in the display. You now have the option of changing the value.

## Changing a value of the lubrication cycle duration $t_{sz}$ :

- ▶ If you want to change the value of the lubrication cycle duration  $t_{sz}$ , move the activation and programming key back to the action surface.
- The double circle appears and the next higher ( $t_{sz \text{ actual} + 1}$ ) adjustable value of the lubrication cycle duration is shown in the display. The double circle lights up for as long as the activation and programming key is on the action surface; the other values of the lubrication cycle duration run through one after the other (the display accelerates). However, you can also remove the activation and programming key from the action surface and place it on the action surface again shortly afterwards in order to reach each value individually one after the other. If the final value of the lubrication cycle duration of  $t_{sz} = 240$  is reached and no value was selected, the menu jumps back to  $t_{sz} = 01$  and the run can be started again.
- ▶ When the new value you desire for the lubrication cycle duration ( $t_{sz \text{ new}}$ ) is shown in the display, remove the activation and programming key from the action surface.
- The confirmation hook appears; for visual confirmation, the display and the hook flash twice. The selected new value ( $t_{sz \text{ new}} \Rightarrow t_{sz \text{ actual}}$ ) of the lubrication cycle duration has now been accepted. The submenu now automatically continues to the values of the number of lubrication strokes.

## No changing a value of the lubrication cycle duration $t_{sz}$ :

- ▶ If you do not want to change the value of the lubrication cycle duration  $t_{sz}$ , the activation and programming key must remain away from the action area.
  - The confirmation hook appears; for visual confirmation, the display and the hook flash twice, while the display shows the lubrication cycle duration  $t_{sz}$ . The submenu now automatically continues to the value of the number of lubrication strokes C.
- The display first shows the currently set value for the number of lubrication strokes per pump cycle ( $C_{\text{actual}}$ ). You now have the option of changing the values.

### Changing a value of the number of lubrication strokes C per pump cycle PZ:

- ▶ If you want to change the value of the number of lubrication strokes C, move the activation and programming key back to the action surface.
  - ➔ The double circle appears and the next higher ( $C_{\text{actual} + 1}$ ) adjustable value of the number of lubrication strokes is shown in the display. The double circle lights up for as long as the activation and programming key is on the action surface; the other values of the number of lubrication strokes run through one after the other. However, you can also remove the activation and programming key from the action surface and shortly afterwards return it to the action surface in order to reach each value individually one after the other. If the final value of the number of lubrication strokes of  $C = 10$  is reached and no value was selected, the menu jumps back to  $C = 01$  and the run can be started again.
- ▶ When the new value you desire for the number of lubrication strokes ( $C_{\text{new}}$ ) is shown in the display, remove the activation and programming key from the action surface.
  - ➔ The confirmation hook appears; for visual confirmation, the display and the hook flash twice. The selected new value ( $C_{\text{new}} \Rightarrow C_{\text{actual}}$ ) of the number of lubrication strokes C per pump cycle has now been accepted.

### No changing of the value of the number of lubrication strokes C per pumping cycle PZ:

- ▶ If you do not want to change the value of the number of lubrication strokes C, the activation and programming key must remain away from the action surface.
  - ➔ The confirmation hook appears; for visual confirmation, the display and the hook flash twice, while the display shows the set number of cycles.
- ▶ Reattach the activation and programming key in the opening provided on the underside of the LUB-S.
- ⓘ The Settings menu can only be accessed from ON mode (LUB-S switched on). Once you have entered the Settings menu, you will automatically return to the ON mode.
- ⓘ If you have made changes to the value of the lubrication cycle duration  $t_{\text{SZ}}$  or the value of the number of lubrication strokes C per pump cycle PZ in the Settings menu and the LUB-S is otherwise ready for operation (operating voltage applied and a cartridge fitted), the LUB-S will then immediately start with the newly set lubrication cycle SZ. The integrated time counter of the LUB-S starts counting the new lubrication cycle duration  $t_{\text{SZ}}$  that has just been set.
- ▶ Observe the back pressure values shown in the display if they are of interest to you.
- ⓘ During the pumping cycle, the display shows the back pressure for each lubrication stroke.



## WARNING

**Incorrect settings can cause damage to machinery or equipment.**

- Carefully determine the required lubricant quantity before selecting the settings.
- Set the correct lubricant delivery quantity on the LUB-S.
- Check the lubrication point regularly to see whether the settings made result in overlubrication or insufficient lubrication.

### 6.3.4.2 Operating mode Setting Emptying time

**General information:**

Term/Parameter	Shortcut	Value
Number of lubrication strokes per pump cycle and outlet	C	predefined, 1
Lubrication stroke time	$t_C$	predefined, 7s ... 17s
Relaxation time	$t_E$	predefined, 2s
Pause time	$t_P$	calculable
Pump cycle	PZ	–
Pump cycle duration	$t_{PZ}$	calculable
Lubrication cycle	SZ	–
Lubrication cycle duration	$t_{SZ}$	calculable
Emptying time	EZ	–
Emptying time of a cartridge	$t_{EZ}$	adjustable, 1 ... 36

The different parameters can be calculated as follows:

$$t_{PZ} = t_C$$

$$t_P = t_{SZ} - t_{PZ}$$

Simplified calculation of the **lubrication cycle duration**  $t_{sz}$  [h] depending on the selected cartridge:

	125 ml cartridge	250 ml cartridge
LUB-S	$= t_{EZ} * 30,5d * 24h * \frac{1}{780}$	$= t_{EZ} * 30,5d * 24h * \frac{1}{1560}$

The following graphic explains the parameters and terms in the operating mode Setting emptying time. The graphic shows the example of an LUB-S with 125 ml cartridge.

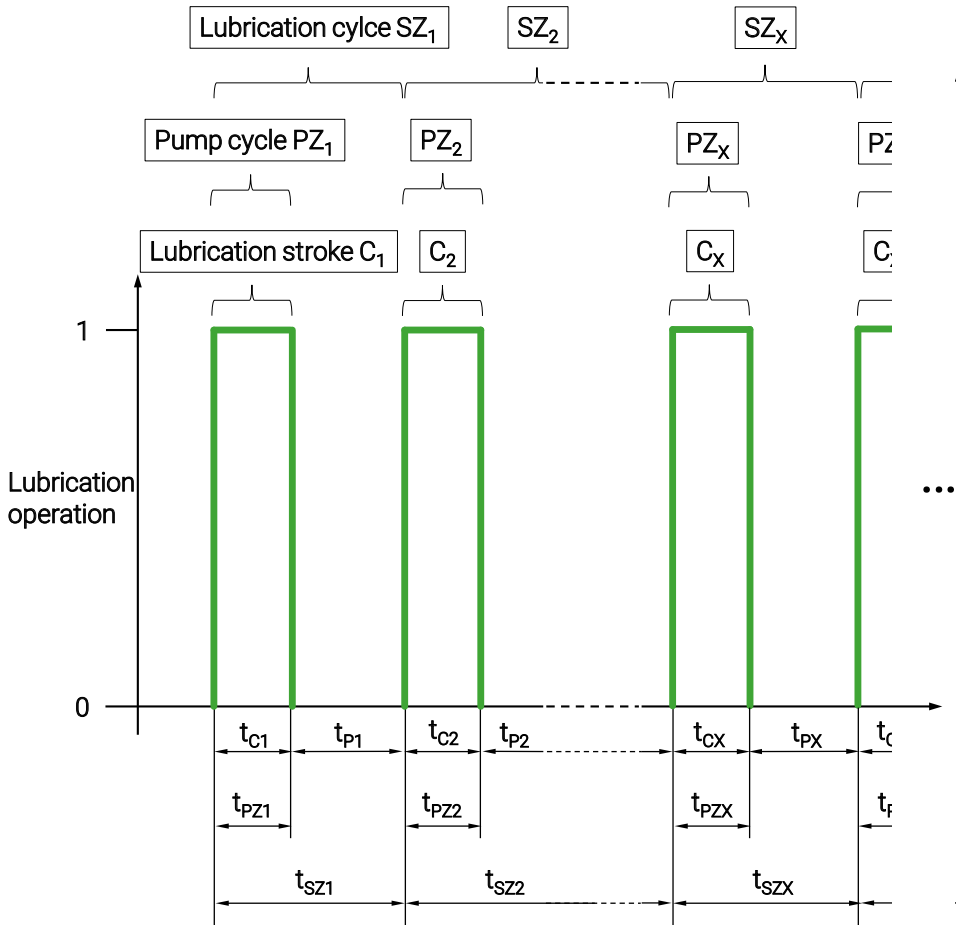

The following graphic explains the parameters and terms in the operating mode Setting emptying time. The graphic shows the example of an LUB-S with 125 ml cartridge.

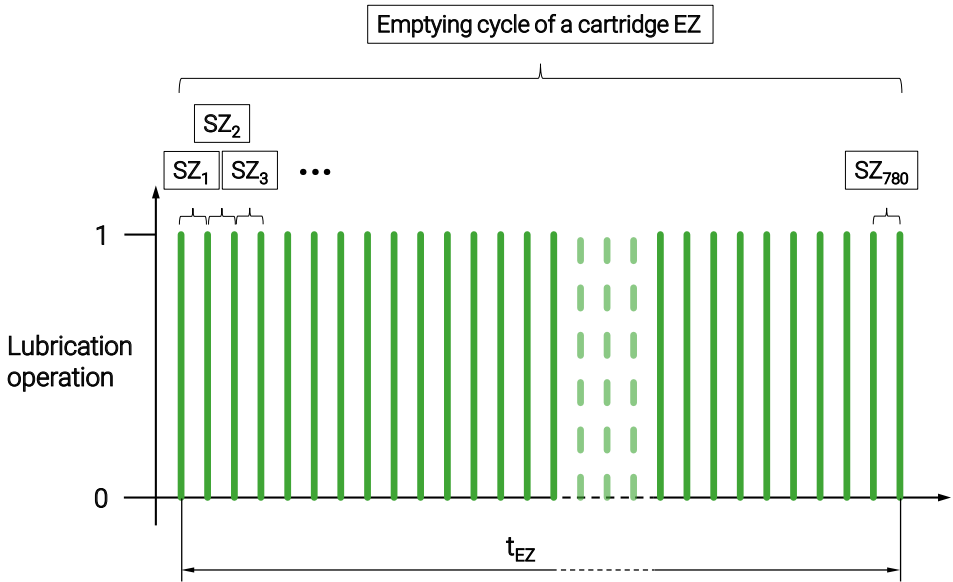

## Default settings Operating mode Setting Emptying time:

Emptying time  $t_{EZ} = 6$  The emptying time  $t_{EZ}$  of the cartridge is 6 months.

ⓘ The default settings result in an emptying time  $t_{EZ}$  (service life) for a full lubricant cartridge with 125 ml or 250 ml content of 6 months when using an LUB-S with one (1) outlet in the operating mode setting emptying time, provided that the LUB-S is permanently switched on and no special lubrication strokes were carried out, e.g. by the filling or quick check menu. The LUB-S calculates a lubrication cycle time of approx. 5.6 hours when using a cartridge with 125 ml content and a lubrication cycle time of approx. 2.8 hours when using a cartridge with 250 ml content. The lubrication cycle duration depends on the number of outlets of the present LUB-S and the selected cartridge size.

► Determine whether the default settings are applicable to your application and whether the lubrication point is supplied with the correct amount of lubricant per time unit. If this is the case, you can operate the LUB-S in the operating mode Setting emptying time with the default settings. If this is **not** the case, change the value for the emptying time  $t_{EZ}$  accordingly: This chapter explains how to make these changes.

ⓘ To use the LUB-S, it must first be properly mounted and installed and then switched on. Mounting is very simple and described in detail in Chap. 5; switching on is described in Chap. 6.3.1

Definitions of the adjustable parameters for the emptying time  $t_{EZ}$  and the number of lubrication strokes C per pump cycle PZ and their respective permissible values:

$t_{EZ} :=$  **emptying time** in months (m).  
The emptying time can be set between 1 | 2 | 3 | ... | 36 months.

## Performing changes:

The Settings menu allows changing specific parameters of the selected operating mode. This chapter explains how to change the specific parameters of the emptying time  $t_{ez}$  in months when the operating mode Setting emptying time is selected.

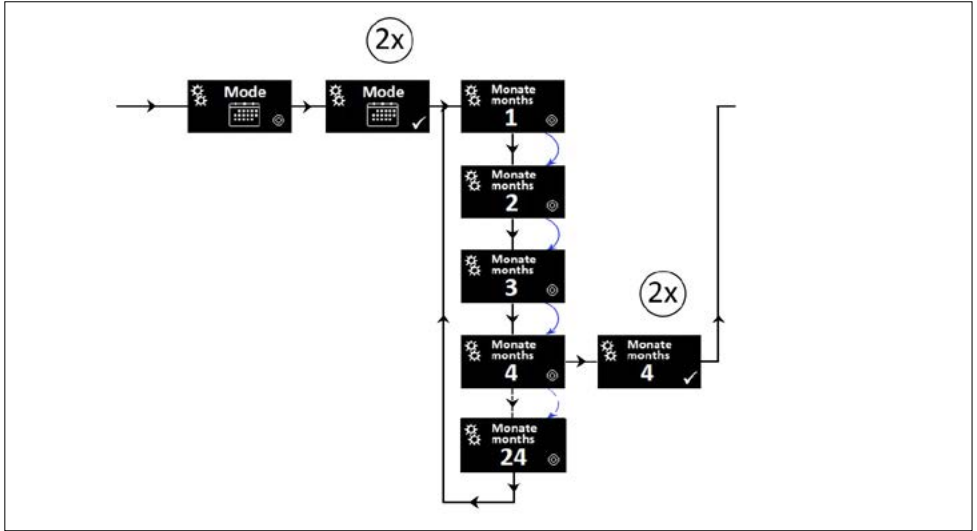

### Procedure:

- ✓ The LUB-S is switched on and there is no fault or error.
- ▶ Remove the activation and programming key from the underside of the LUB-S and place it on the action area.
- ▶ Hold the activation and programming key on the action area. The double circle appears in the bottom right corner. Leave the activation and programming key on the action area until **Settings** appears in the display. Remove the activation and programming key from the action area until Settings appears in the display. The double circle disappears.
- ⇒ The confirmation hook appears; the display and the hook flash twice for visual confirmation.

## Changing the emptying time $t_{EZ}$ :

As soon as the Settings menu has been selected, the active operating mode is displayed. To be able to set the emptying time  $t_{EZ}$ , the operating mode Setting emptying time with the calendar symbol must be selected. If this is not the case, change the operating mode accordingly. An explanation of how to change the operating mode can be found in Chap. 6.3.4.

After the display of the operating mode Setting emptying time, the emptying time  $t_{EZ}$  in months can be set.

- In addition to the display of the active operating mode, the confirmation hook appears; the display and the hook flash twice for visual confirmation.
- In the next step, the currently set value of the emptying time ( $t_{EZ \text{ actual}}$ ) is shown in the display. You now have the option of changing the value.

## Changing a value of the emptying time $t_{EZ}$ :

- ▶ If you want to change the value of the emptying time  $t_{EZ}$ , move the activation and programming key to the action area again.
- The double circle appears and the next higher ( $t_{EZ \text{ actual} + 1}$ ) adjustable value of the emptying time is shown in the display. The double circle lights up as long as the activation and programming key is on the action surface; the other values of the emptying time run through one after the other. However, you can also remove the activation and programming key from the action surface and shortly afterwards return it to the action surface in order to reach each value individually one after the other. If the final value of the emptying time of  $t_{EZ} = 36$  is reached and no value was selected, the menu jumps back to  $t_{EZ} = 01$  and the run can be started again.
- ▶ When the new value you desire for the emptying time ( $t_{EZ \text{ new}}$ ) is shown in the display, remove the activation and programming key from the action surface.
- The confirmation hook appears; for visual confirmation, the display and the hook flash twice. The selected new value ( $t_{EZ \text{ new}} \Rightarrow t_{EZ \text{ actual}}$ ) of the emptying time has now been accepted.

## No changing a value of the emptying time $t_{EZ}$ :

- ▶ If you do not want to change the value of the emptying time  $t_{EZ}$ , the activation and programming key must remain away from the action area.
- The confirmation hook appears; for visual confirmation, the display and the hook flash twice, while the display shows the emptying time  $t_{EZ}$ .
- ▶ Reattach the activation and programming key in the opening provided on the underside of the LUB-S.

① The Settings menu can only be accessed from ON mode (LUB-S switched on). Once you have entered the Settings menu, you will automatically return to the ON mode.

① If you have made changes to the value of the emptying time  $t_{ez}$  or the value of the number of lubrication strokes C per pump cycle PZ in the Settings menu and the LUB-S is otherwise ready for operation (operating voltage applied and a cartridge fitted), the LUB-S will then immediately start with the newly set lubrication cycle SZ. The integrated time counter of the LUB-S starts counting the new emptying time  $t_{ez}$  that has just been set.

► Observe the back pressure values shown in the display if they are of interest to you.

① During the pumping cycle, the display shows the back pressure for each lubrication stroke.



## WARNING

### **Incorrect settings can cause damage to machinery or equipment.**

- Carefully determine the required lubricant quantity before selecting the settings.
- Set the correct lubricant delivery quantity on the LUB-S.
- Check the lubrication point regularly to see whether the settings made result in overlubrication or insufficient lubrication.

## 6.3.4.3 Operating mode pulse control

No specific settings can be changed in the Settings menu within the operating mode Pulse control, since the LUB-S is integrated into a control system (PLC) and is commanded and controlled via the PLC, see Chap. 8. Only the operating mode and the cartridge size can be set here, see Chap. 6.3.4.

Any other control signals can only be sent by the PLC.

### Default settings Pulse control mode:

In the pulse control operating mode, the LUB-S must be integrated into a control system (PLC) and commanded and controlled via this. In this case, a lubrication stroke/several lubrication strokes (one stroke = 0.15 ml) is/are triggered at the LUB-S depending on signals from the external control (PLC).

- ▶ Make sure that your PLC program is applicable to your application and that the lubrication point is supplied with the correct amount of lubricant per time unit. If this is the case, you can operate the LUB-S in pulse control mode. If this is **not** the case, modify your PLC program accordingly.

ⓘ To use the LUB-S, it must first be properly mounted and installed and then switched on. Mounting is very simple and described in detail in Chap. 5; switching on is described in Chap. 6.3.1.



### DANGER

**Machine elements that are not lubricated can cause failures resulting in serious injury or death.**

- After sending a control signal, the response signal of the LUB-S must be waited for, evaluated and interpreted in order to prevent an uncontrolled failure of the LUB-S.

## 6.3.5 Activate the Filling-menu

The filling command enables you to trigger a defined multiple dispensing at the LUB-S. A pump cycle PZ with a total of 40 lubrication strokes C is initiated with the activation. This function enables you to pre-fill connected accessories (tubes, distributors, etc.) with the lubricant contained in the lubricant cartridge, especially during the initial commissioning of the LUB-S. The process can be interrupted manually at any time.

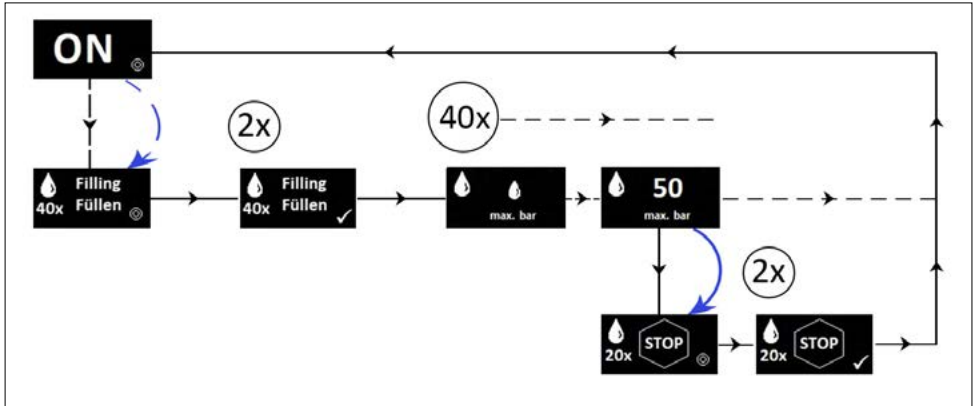



✓ The LUB-S is switched on and there is no fault or error.

- ▶ Remove the activation and programming key from the underside of the LUB-S and place it on the action area.
- ▶ Hold the activation and programming key on the action area. The double circle appears in the bottom right corner. Leave the activation and programming key on the action area until **Filling** appears in the display. Remove the activation and programming key from the action area until Filling appears in the display. The double circle disappears.
- ⇒ The confirmation hook appears; the display and the hook flash twice for visual confirmation.
- ▶ If you do not want to cancel the process: Reattach the activation and programming key in the opening provided for this purpose on the underside of the LUB-S.
- ⇒ The LUB-S delivers 40 strokes of lubricant.

- ▶ If you want to cancel the operation: Move the activation and programming key to the action area during the pump cycle PZ and wait until the STOP symbol appears in the display. Remove the activation and programming key from the action surface as long as STOP is shown in the display. The double circle disappears.
  - ➡ The confirmation hook appears; the display and the hook flash twice for visual confirmation.
  - ➡ The LUB-S cancels the filling function. In addition, the number of complete lubrication strokes is shown in the display.
  
- ▶ Observe the back pressure values shown in the display if they are of interest to you.
  
- ⓘ If you use the Filling menu in the operating mode Setting emptying time, this will have a shortening effect on the set emptying time.
  
- ⓘ The Filling menu can only be reached from the ON mode (LUB-S switched on). If you have activated the Fill command, you will automatically return to ON mode.

## 6.4 Error and information messages on the display

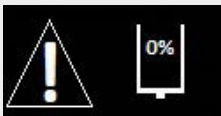
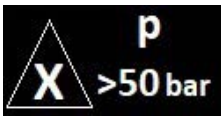
The integrated microelectronic in the LUB-S permanently monitors the status. In case of abnormalities, an addressed message is issued and shown on the display. If the LUB-S has detected an error and issues an error message for better identification of the error, no more lubricant is pumped. In addition, the screen saver changes and gives an indication of the type of error by displaying the error number. The errors must be eliminated after they occur. If you operate the LUB-S in the operating modes Setting lubrication cycle duration or Setting emptying time, errors must be acknowledged on the display. If the LUB-S is operated in pulse control mode, the errors can only be acknowledged by the PLC by sending a specific signal, see Chap. 8.2.

Symbol	Name	Explanation	Remedy
	Error E1	No cartridge mounted	<ul style="list-style-type: none"> <li>● Place a cartridge on the LUB-S (see chapter 5.4)</li> </ul>
	Note N1	Cartridge empty	<ul style="list-style-type: none"> <li>● Place a new cartridge on the LUB-S (see chapter 9.2)</li> <li>① No acknowledgement of the note is necessary; it is automatically deleted after the cancellation measure..</li> </ul>
	Error E2	Overpressure; the counter-pressure at the lubrication point is too high	<ul style="list-style-type: none"> <li>● Check the lubrication point and eliminate the cause.</li> <li>● Then trigger a Quick-Check for self-testing of the LUB-S or disconnect the power supply.</li> </ul>
	Error E3	Under- or overvoltage	<ul style="list-style-type: none"> <li>● Switch off the LUB-S (OFF).</li> <li>● Check the power supply of the LUB-S.</li> <li>● Switch on LUB-S (ON).</li> </ul>
	Error E4	Device error	<ul style="list-style-type: none"> <li>● Disassemble the LUB-S and return it to the manufacturer together with the lubricant cartridge and a description of the fault.</li> <li>① A serious fault is usually in the electronics of the LUB-S and cannot be repaired by you on site.</li> </ul>

Symbol	Name	Explanation	Remedy
		Control signal unknown	<ul style="list-style-type: none"> <li>▶ Change the length of the input signal.</li> <li>▶ See „8.2 Input signals – External control (PLC)“.</li> </ul>

If the cause of an error message on the LUB-S has been searched for, found and eliminated and the error has been acknowledged on site or by the PLC, the LUB-S automatically returns to automatic mode. If the error message persists despite the elimination of the cause, or if it occurs repeatedly, the LUB-S must be sent to the manufacturer. To do this, disassemble the LUB-S and return it to the manufacturer together with the lubricant cartridge and a description of the error.

## 6.5 Empty level warning

The microelectronic integrated in the LUB-S permanently monitors the status. The LUB-S warns you on the display that the cartridge will soon be empty if it falls below approx. 15% residual filling quantity. In addition, the LUB-S shows the remaining filling quantity in % on the display after the empty level warning has been activated. In this way, you can follow the progress of the filling level and reorder a new cartridge in good time before the complete empty level is reached.

Symbol	Name	Explanation
	Empty level warning	Residual amount inside the cartridge approx. 15%.



NOTE

A used lubricant cartridge must not be put back on LUB-S-V as the integrated stroke counter of LUB-S-V is automatically reset by the cartridge sensor after a cartridge has been removed. Only use full lubricant cartridges.

## 7. Output signals – Time control

The LUB-S operates in the time control mode (Operating modes setting lubrication cycle duration or emptying time) as a time-based and cycle-controlled lubricator according to the values set in the Settings menu.

### 7.1 Pin assignment – Time control

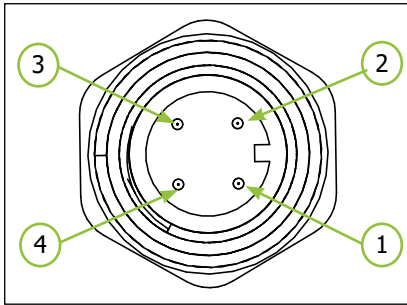

#### Pin assignment – Time control

PIN	Assignment	Colour
1	+24 V DC	brown
2	unallocated	white
3	Ground	blue
4	Output signal	black

Type: M12x1 female connector; 4-pin, A-coded

The LUB-S can be switched off completely in the time control mode by switching off the supply voltage. The settings made are not lost in the process. The time elapsed until the next scheduled lubrication cycle is automatically stored by the LUB-S in the integrated microelectronics; after the supply voltage is reconnected, the LUB-S checks itself automatically and constantly processes the remaining pause time according to the set values.

ⓘ After a longer standstill of the LUB-S, the manual execution of the „Quick-Check“ is recommended (chap.6.3.3).

ⓘ The output signal at PIN 4 can be tapped for further processing (e.g. indicator light or external control). The maximum permissible output current must not exceed  $I_{max} < 20\text{mA}$ . No inductive load (e.g. relay) may be connected!

## 7.2 Output signals – Time control

The present LUB-S provides three output signals in the time control via the electrical interface. Basically, the output signals can only be sampled and must not be subjected to inductive load or low ohmic load. This enables – in addition to the optical indication via the display on the LUB-S – also the status control from a distance.

Output signal (PIN 4)	Meaning	Description
0,5 Hz-Square wave signal, permanent	Note N1 Empty cartridge	The integrated microelectronic of the LUB-S is equipped with an automatic counter which counts the number of lubrication strokes. If this signal is present, the LUB-S will not deliver any lubricant! Remedial measures can be found in Chap. 9.2.
low, permanent	Error E1 Error E2 Error E3 Error E4	A permanent low level (0V) at PIN 4 means that there is an error. The error must be read on the display of the LUB-S (chap. 6.4). The LUB-S does not deliver lubricant!
high, permanent	LUB-S is switched off LUB-S is operating correctly	A permanent high level (+24 V DC) at PIN 4 means that the LUB-S is working correctly and that there is no error or that LUB-S was switched off (OFF).

## 8. Input and output signals – External control (PLC)

To command the LUB-S via an external control (PLC), it is necessary to switch the LUB-S to pulse control mode in the Settings menu (chap.6.3.4.1).

The LUB-S operates in pulse control mode as a pulse-controlled lubrication system only if unalterable control signals of defined length are transmitted from the PLC to the LUB-S via PIN 2. The LUB-S signals the respective condition to the PLC via high/low levels, which must be tapped at PIN 4, and thus enables comprehensive control of the various conditions. For the integration of the LUB-S into an external control system, one input and one output each must be provided on the control side.

	DANGER
	<p><b>Machine elements that are not lubricated can cause failures resulting in serious injury or death.</b></p> <ul style="list-style-type: none"> <li>To operate the LUB-S via an external controller (PLC) in pulse control mode, a program corresponding to the communication protocol must be created in the PLC.</li> <li>After sending a control signal, the response signal of the LUB-S must be waited for, evaluated and interpreted in order to prevent an uncontrolled failure of the LUB-S.</li> </ul>

### 8.1 Pin assignment – External control (PLC)

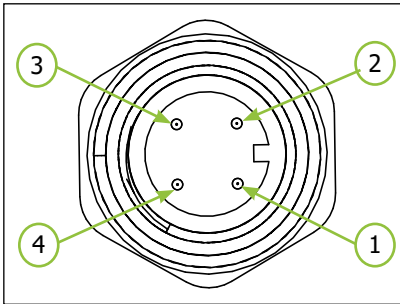

PIN-Assignment-external control (PLC):

PIN	Assignment	Colour
1	+24 V DC	brown
2	Input Signal PLC → LUB-S	white
3	Ground	blue
4	Output Signal LUB-S → PLC	black

Type: M12x1 female connector; 4-pin, A-coded

For the electrical connection to the external control system (PLC) of a machine, the LUB-S has a 4-pin interface, which is designed as a plug-in connection with the industry-standard M12x1 connection.

ⓘ The LUB-S can be switched off completely in pulse control mode by switching off the supply voltage. The settings made are not lost in the process. After the supply voltage is reconnected, the LUB-S checks itself automatically and does not operate until it receives a control signal from the PLC.

ⓘ The output signal at PIN 4 must be tapped at an external control for further processing. The maximum permissible output current must not exceed  $I_{max} < 20\text{mA}$ . No inductive load (e.g. relay) may be connected!

ⓘ After a longer standstill of the LUB-S, it is recommended to trigger the control signal „1 lubrication stroke“ manually (100 ms).

## 8.2 Input signals – External control (PLC)

The LUB-S provides the following invariably defined control signals (input signals), which must be transmitted from the PLC to the LUB-S via PIN 2 of the electrical M12x1 interface as high level (+24 V DC). The control signals must be generated as high level (+24 V DC) by the external control (PLC) over specific times, each with a tolerance of  $\pm 25$  milliseconds.

The LUB-S processes the following control/input signals:

Signal length I [ms]	Function	Detail
100	1 lubrication stroke	Chap. 8.2.1
900	Filling	Chap. 8.2.2
1000	Cancel filling	Chap. 8.2.3
1600	Status request (sign of presence)	Chap. 8.2.4
1700	Acknowledge error	Chap. 8.2.5

ⓘ The LUB-S in pulse mode only processes the control signals listed in the table up to a maximum length of  $1700 \pm 25$  milliseconds. If a high level (+24 V DC) is present outside the tolerances, the LUB-S returns a message for an impermissible control signal as a response, see Chap. 8.3. If a high level (+24 V DC) is present at PIN 2 of the electrical interface for longer than 1725 milliseconds, the LUB-S also returns a message for an impermissible control signal as a response, see Chap. 8.3.

ⓘ LUB-S-V continues to process the signal lengths used by devices between 2010 and 2022! (2 seconds: 1 stroke, 12 seconds: Filling function, 14 seconds: Acknowledge error) The length of the first signal received determines which control signals it reacts to. A changeover is made by interrupting the voltage for a few seconds.

ⓘ The following diagram shows the general characteristics of a control signal that must be generated by the PLC or external controller and sent to the LUB-S controller via PIN 2.

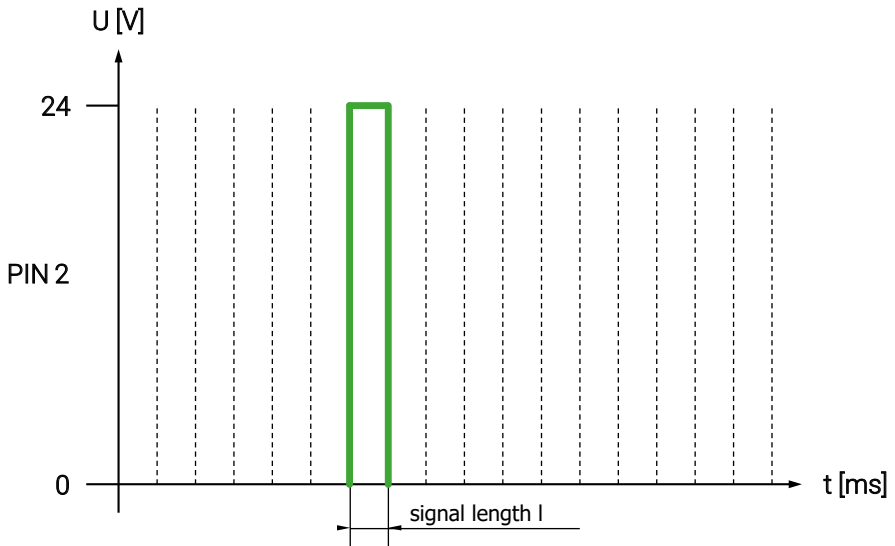

### 8.2.1 Control/input signal „1 lubrication stroke“

The control signal „1 lubrication stroke“ triggers a single lubrication stroke.

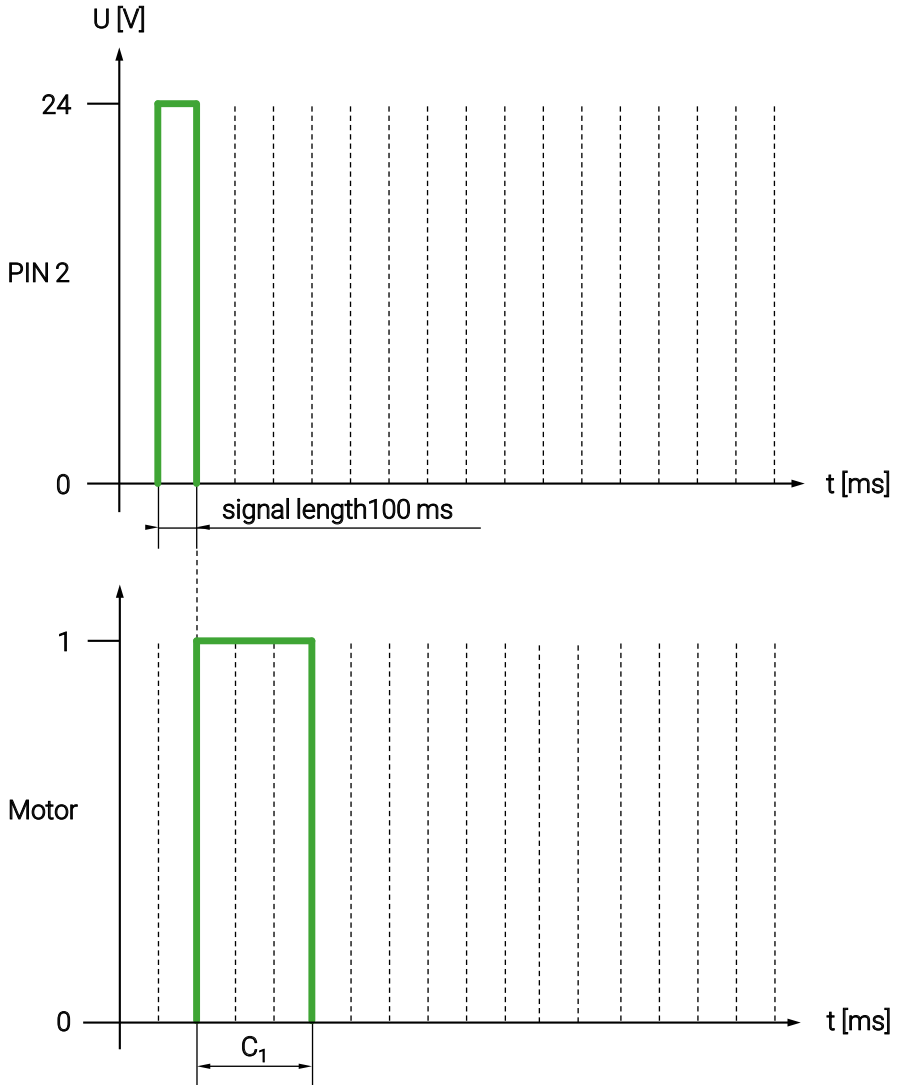

## Description:

- ✓ The LUB-S is properly connected to an external controller via the electrical interface and connected to the power supply.
  - ✓ Pulse control mode is activated on the LUB-S.
  - ✓ There are no errors on the LUB-S; the LUB-S is ready for operation.
- 
- The LUB-S sends a permanent output signal (high level) to PIN 4, which indicates readiness for operation to the external controller (PLC). This output signal must be present permanently and uninterruptedly for >500 milliseconds. Only if this prerequisite is fulfilled, an activation by the external control is possible at all.
  - The control signal „1 lubrication stroke“ with signal length of 100 (75 ... 125) milliseconds high level can be sent from the external control (PLC) to the LUB-S.
  - While a high level is present at PIN 2 of the LUB-S as an input signal from the external controller (PLC), the symbol indicating the pulse control operating mode flashes in the display for the length of the signal.
  - Immediately after the control signal drops, the lubrication stroke C of the LUB-S starts and 0.15 ml of lubricant is delivered to the outlet. The LUB-S monitors this lubrication stroke for the entire duration.
  - The lubrication stroke time depends on various conditions, including the counterpressure present or built up in the hydraulic system and the temperature. For the LUB-S, the lubrication stroke duration is 7...17 seconds ( $t_C = 7...17$  seconds).
  - During the lubrication stroke C, a numerical value 1...70 is shown in the display, which indicates the approximate back pressure in bar. The back pressure is displayed in relation to the outlet.
  - At the end of a lubrication stroke C, the LUB-S sends an output signal to PIN 4, which provides information about the past lubrication stroke as well as other states of the LUB-S for evaluation at a PLC or other external controller (see chapter 8.3).
- 
- ⓘ At the earliest >500 milliseconds after the end of the response signal, a possible next control signal can be sent from the external control (PLC). For the characteristics and interpretation of the output signal, refer to Chap. 8.3. In the meantime, the LUB-S does not process any control signals.
- 
- ⓘ If the integrated microelectronic of the LUB-S has detected an error during or immediately after the end of the lubrication stroke, it will be transmitted to the external control (PLC) by the corresponding output signal.

### 8.2.2 Control/input signal „Filling“

The „Filling“ control signal triggers the filling function by the external control. A total of 40 lubrication strokes are performed automatically one after the other.

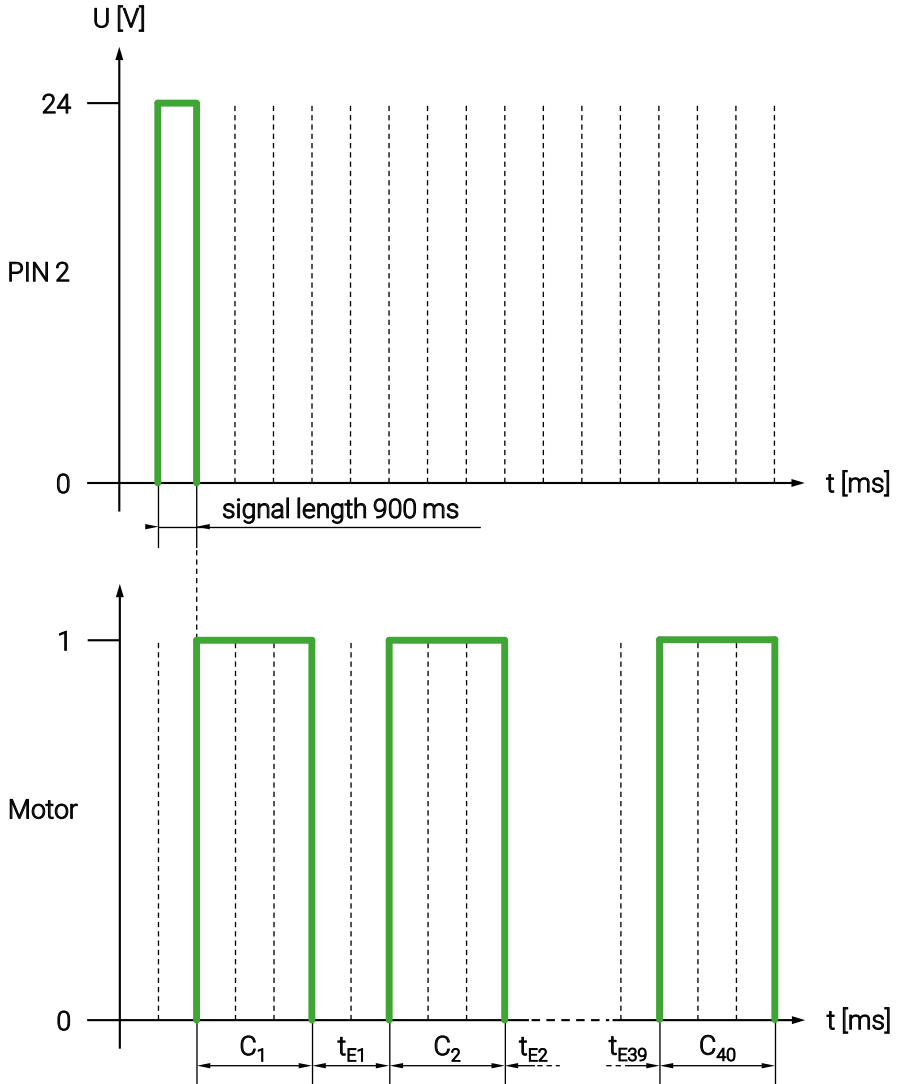

## Description:

- ✓ The LUB-S is properly connected to an external controller via the electrical interface and connected to the power supply.
  - ✓ Pulse control mode is activated on the LUB-S.
  - ✓ There are no errors on the LUB-S; the LUB-S is ready for operation.
- 
- The LUB-S sends a permanent output signal (high level) to PIN 4, which indicates readiness for operation to the external controller (PLC). This output signal must be present permanently and uninterruptedly for >500 milliseconds. Only if this prerequisite is fulfilled, an activation by the external control is possible at all.
  - The control signal „Filling“ with signal length of 900 (875 ... 925) milliseconds high level can be sent to the LUB-S from the external control (PLC).
  - While a high level is present at PIN 2 of the LUB-S as an input signal from the external controller (PLC), the symbol indicating the pulse control operating mode flashes in the display for the length of the signal.
  - Immediately after the control signal drops, the lubrication stroke C of the LUB-S starts and 0.15 ml of lubricant is delivered to the outlet. The LUB-S monitors this lubrication stroke for the entire duration.
  - The lubrication stroke time depends on various conditions, including the counterpressure present or built up in the hydraulic system and the temperature. For the LUB-S, the lubrication stroke duration is 7...17 seconds ( $t_C = 7...17$  seconds).
  - During the lubrication stroke C, a numerical value 1...70 is shown in the display, which indicates the approximate back pressure in bar. The back pressure is displayed in relation to the outlet.
  - At the end of a lubrication stroke C, the LUB-S sends an output signal to PIN 4, which provides information about the past lubrication stroke as well as other states of the LUB-S for evaluation at a PLC or other external controller (see chapter 8.3).
  - A total of 40 lubrication strokes C and 39 relaxation phases tE of two seconds length take place in immediate succession between the lubrication strokes. In the process,  $40 \times 0.15 \text{ ml} = 6.0 \text{ ml}$  of lubricant are delivered from the cartridge to the outlet.
- 
- ⓘ At the earliest >500 milliseconds after the end of the last output signal, a possible next control signal can be sent from the external control (PLC). During the filling function, the control signal „Cancel filling“ (chap.) is the only control signal that the LUB-S can process.
  - ⓘ If the integrated microelectronic of the LUB-S has detected an error during or immediately after the end of the lubrication stroke, it will be transmitted to the external control (PLC) by the corresponding output signal (chap.7.2).
  - ⓘ The filling function can be stopped with the „Cancel filling“ control signal, see section 8.2.3.

### 8.2.3 Control/input signal „Cancel filling“

The „Cancel filling“ control signal can be used to stop the filling function activated by the „Filling“ control signal. During the filling function, the „Cancel filling“ control signal is the only control signal that the LUB-S can process.

#### **Description:**

- ✓ The LUB-S is properly connected to an external controller via the electrical interface and connected to the power supply.
- ✓ Pulse control mode is activated on the LUB-S.
- ✓ The filling function has been activated by the „Filling“ control signal.
  
- The LUB-S carries out the filling function.
- The control signal „Cancel filling“ with a signal length of 1000 (975 ... 1025) milliseconds high level can be sent from the external control (PLC) to the LUB-S during the relaxation time  $t_E$  between two lubrication strokes  $C$ .
- At the end of the transmission of the „Cancel filling“ control signal, the LUB-S stops the filling function directly. If the „Cancel filling“ control signal is sent during a lubrication stroke, the current lubrication stroke is completed and then the filling function is canceled.
  
- ① At the earliest >500 milliseconds after the end of the response signal, a possible next control signal can be sent from the external control (PLC). For the characteristics and interpretation of the output signal, refer to Chap. In the meantime, the LUB-S does not process any control signals.

## 8.2.4 Control/input signal „Status request“

The „Status request (sign of presence)“ control signal can be used to check the last status of the LUB-S and the last lubrication stroke. In addition, the „Status request (sign of presence)“ control signal can be used to cyclically check whether the LUB-S can be reached.

### Description:

- ✓ The LUB-S is properly connected to an external controller via the electrical interface and connected to the power supply.
- ✓ Pulse control mode is activated on the LUB-S.
  
- A high level is applied to PIN 4 of LUB-S for >500 milliseconds.
- The control signal „Status request (sign of presence)“ with signal length of 1600 (1575 ... 1625) milliseconds high level can be sent from the external control (PLC) to the LUB-S.
- After the end of the transmission of the control signal „Status request (sign of presence)“, the LUB-S repeats the output signal of the past lubrication stroke on PIN 4.
  
- ⓘ At the earliest >500 milliseconds after the end of the response signal, a possible next control signal can be sent from the external control (PLC). For the characteristics and interpretation of the output signal, refer to Chap. 8.3. In the meantime, the LUB-S does not process any control signals.

## 8.2.5 Control/input signal „Acknowledge error“

The „Acknowledge error“ control signal is used to acknowledge the E2 overpressure or E3 over/undervoltage errors after they have occurred previously and have been communicated by the LUB-S to the PLC. It is the only control signal that the LUB-S can process if an error message was sent in response to the previous motor run. Regardless of the principle possibility of remote acknowledgement of an error, it is essential to identify and eliminate the cause when an error message is present.

### Description:

- ✓ The LUB-S is properly connected to an external controller via the electrical interface and connected to the power supply.
- ✓ Pulse control mode is activated on the LUB-S.
- ✓ There is an E2 or E3 error at LUB-S.

- The output signal sent from the LUB-S to PIN 4 to the external controller reports an error message E2 or E3 back.
- An identification of the cause of the error message has taken place on the LUB-S and it has been eliminated.
- The control signal „Acknowledge error“ with signal length of 1700 (1675 ... 1725) milliseconds high level can be sent from the external control (PLC) to the LUB-S.
- After the end of the control signal, the integrated microelectronic checks the LUB-S independently:
  - If this internal check is **successful**, the error E2 or E3 is thus acknowledged and the LUB-S is ready for operation again.
  - If this internal check is not successful, the LUB-S continues to send an output signal that defines an error. The error is still present. In this case, check the lubrication point and the LUB-S again and then send the „Acknowledge error“ control signal again. If the second check is again unsuccessful, disassemble the LUB-S with the lubricant cartridge screwed on and return the complete lubrication system to the manufacturer with a detailed description of the error.

ⓘ At the earliest >500 milliseconds after the end of the response signal, a possible next control signal can be sent from the external control (PLC). For the characteristics and interpretation of the output signal, refer to Chap. In the meantime, the LUB-S does not process any control signals.

## 8.3 Output signals – External control (PLC)

The LUB-S has invariably defined output signals that are transmitted to the PLC via PIN 4 of the M12x1 electrical interface depending on the condition of the LUB-S.

Each time a control signal is sent from the PLC to the LUB-S, the LUB-S sends an output signal after the action caused by the control signal has been executed, which must be waited for, evaluated and interpreted by a suitable PLC program.

A high level (+ 24 V DC) is permanently present at PIN 4. During the transmission of the output signal, the signaling for information transmission changes several times from a high level to a low level and back again. After sending an output signal, a high level is permanently present at PIN 4.

The following graphic shows an example of an output signal.

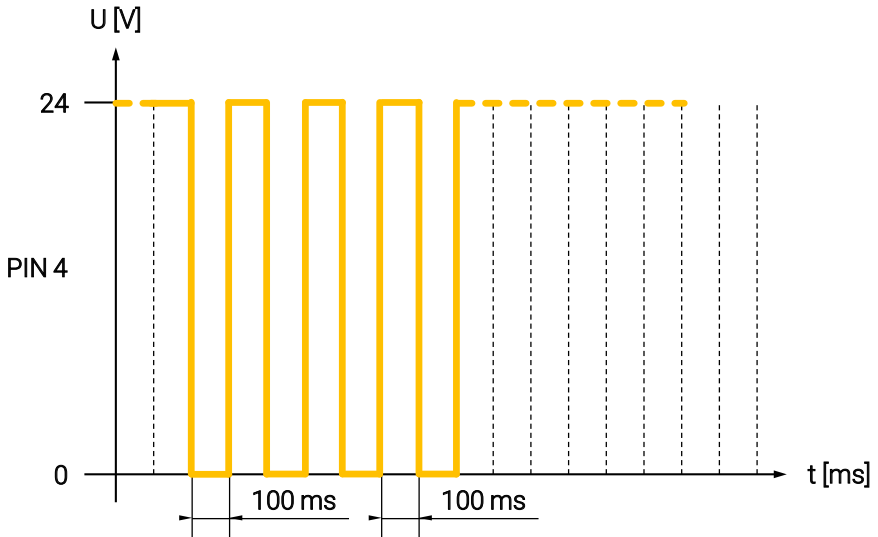

Information about the status of the LUB-S and about the past motor run must be evaluated via an evaluation of the number of edge changes of the output signal. For the evaluation of the edge changes, the rising edge (change of the output voltage at PIN 4 of the LUB-S from a low level (0 V) to a high level (+24 V DC)) must always be counted. The counted number of edge changes corresponds to a one-to-one state of the LUB-S.

The output signal is sent with a frequency of  $f = 5 \text{ Hz}$ . The low level is a voltage of + 0 to 5 V DC, the high level is a voltage between + 17 and + 27 V DC.

The following table shows all the output signals that are sent from the LUB-S to the external controller depending on its status.

Number of edge changes	Information	Remedy
1	Filling function canceled	none necessary, purely informative
2	Past lubrication stroke OK	none necessary, purely informative
3	Past lubrication stroke OK, cartridge soon empty	Buy a new cartridge in time.
4	For past lubrication stroke Overpressure (E2)	<ul style="list-style-type: none"> <li>▶ Check the lubrication point and eliminate the cause</li> <li>▶ Acknowledge error (Chap. 8.2.5)</li> </ul>
12	Cartridge empty	<ul style="list-style-type: none"> <li>▶ Change the cartridge (see chap. 9.2)</li> <li>ⓘ No need to acknowledge the error; it is automatically cleared after the shutdown action.</li> </ul>
14	Over-/undervoltage (E3)	<ul style="list-style-type: none"> <li>▶ Check the power supply of the LUB-S.</li> <li>▶ Acknowledge error (Chap. 8.2.5)</li> </ul>
15	Internal device error (E4)	Disassemble the LUB-S and return it to the manufacturer together with the lubricant cartridge and a description of the fault.
16	Inadmissible, undefined control signal received	Check the PLC program for operating the LUB-S for correctness.



## DANGER

**Machine elements that are not lubricated can cause failures resulting in serious injury or death.**

- After sending a control signal, the response signal of the LUB-S must be waited for, evaluated and interpreted in order to prevent an uncontrolled failure of the LUB-S.

ⓘ If there is a low level at PIN 4 in pulse mode, but the operating voltage is connected, check the connection cable from external control to PIN 4 of the LUB-S. If you cannot detect a problem during the check, a serious device error has occurred that cannot be remedied by you on site. In this case, disassemble the LUB-S with the lubricant cartridge screwed on and return the complete lubrication system to the manufacturer with a detailed description of the fault.

ⓘ The LUB-S always sends a specific output signal within 30 sec. after sending an arbitrary control signal. If this is not the case and the LUB-S no longer responds to any control signal, a time-out has been detected. To check the communication readiness of the LUB-S in this case, send the control signal „Status request (sign of presence)“. If again >30 sec. pass without a response signal from the LUB-S, disconnect the supply voltage from the LUB-S for at least 10 sec. and send the control signal „Status request (sign of presence)“ again after reconnecting the supply voltage. If communication with the LUB-S is still not possible, disassemble the LUB-S with the lubricant cartridge screwed on and return the complete lubrication system to the manufacturer with a detailed description of the error.

## 9. Maintenance and disposal

- ▶ Before starting any (maintenance) work, inform yourself about the general safety instructions (see chapter 2.7) and observe the relevant local and company safety regulations.
- ▶ Do not disable any protective device without authorization!

### 9.1 Maintenance schedule

Maintenance	Commissioning	Yearly	If necessary
Cleaning	x	x	x*
Visual check	x	x	x*
Cartridge change	x**	x***	x*

- \* Depending on operating conditions and lubricant consumption.
- \*\* Dependent on delivery condition (ordered version)
- \*\*\* Recommendation after 2 years at the latest

## 9.1.3 Visual inspection

- ▶ Check the entire lubrication system (LUB-S as well as possibly connected accessories including lines and distributors) by means of a thorough and conscientious visual inspection for external damage (e.g. loose or loosened lines).
- ▶ Check the condition of the lubrication point for correct supply of lubricant.
- ▶ Replace damaged or defective parts immediately to ensure permanent and continuous lubrication.
- ▶ Check the filling level of the cartridge on the LUB-S.
- ▶ Check possible error messages on the LUB-S and eliminate the causes accordingly.

## 9.1.1 Cleaning

- ▶ Clean the LUB-S with suitable means (e.g. absorbent wipes, towels) to remove dirt.



### NOTE

**Pressurised air can damage the seals of the LUB-S and can transport dirt and foreign matter into the LUB-S or the lubricant.**

- Do not use pressurised air.
- Make sure that there is no coarse dirt in the mounting area.

## 9.1.2 Recommissioning after maintenance

- ▶ Reassemble all safety devices and make sure that no tool remains in the danger zone.
- ▶ Check that the LUB-S is switched on.
- ▶ Perform a „Quick-Check“ (test run).

## 9.2 Cartridge change



### NOTE

**Only use original lubricant cartridges with lubricant approved by the manufacturer.**

- Observe the maximum storage life of lubricant filled in cartridges.



### NOTE

**Make sure that you use the same lubricant in the new cartridge which is already in use. Make sure that you only use cartridges with the same filling quantity.**

- Compare the information on the new lubricant cartridge with the information on the old lubricant cartridge.

The cartridge only needs to be changed when it is empty or the service life of the lubricant has been exceeded. A cartridge can be changed during normal operation of the LUB-S. No further measures are necessary apart from changing the cartridge!

ⓘ Observe the signaling of the empty cartridge by the LUB-S described in chap. 6.4, chap. 7.2 or chap. 8.3 when using the LUB-S in pulse control mode.

### 1. Unscrew the empty cartridge from the LUB-S.

▶ Turn the cartridge counterclockwise from the LUB-S and dispose it properly after completion of the work.

ⓘ Pay attention to cleanliness during the work. Make sure that dirt and foreign bodies do not get into the lubricant inlet. If necessary, carry out cleaning work beforehand (chapter 9.1.1)

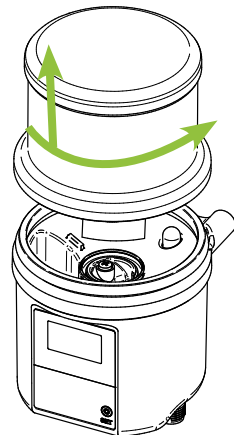

## 2. Disassemble the cap of the new cartridge.

► Turn the cap on the new lubricant cartridge counterclockwise and pull it off.

ⓘ Pay attention to cleanliness during the work. Make sure that dirt and foreign bodies do not get into the lubricant inlet.

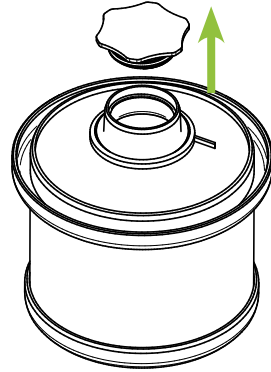

## 3. Only when replacing/installing LUB-S oil cartridges

► Push the PU foam into the cartridge opening up to the edge.

ⓘ This step is only necessary when installing oil cartridges to prevent the cartridge from leaking. The PU foam remains in the cartridge.

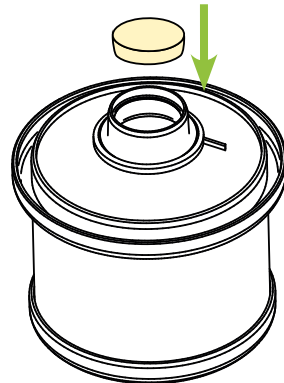

## 4. Mounting the new lubricant cartridge.

- ▶ Place the full lubricant cartridge on the LUB-S with the label facing forward.
- ▶ Turn the lubricant cartridge clockwise until it physically stops on the LUB-S.

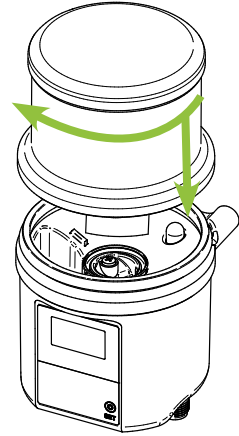

ⓘ The end position should be reached after 2 full rotations when the label of the lubricant cartridge is aligned with the front foil of the LUB-S.

- ▶ Carry out the work according to the above description.
- ➡ If a message was shown in the display before the cartridge was changed, the message now disappears. A separate acknowledgement is not required.
- ➡ After completion of this work, the LUB-S automatically returns to the last active mode (ON or OFF) before the work.
- ⓘ If the empty cartridge level (note N1) has been reached during a pumping cycle, the cycle will be automatically interrupted and automatically continued after completion of the work.

## 9.3 Disposal

- ▶ Observe the relevant national valid regulations for the disposal of the LUB-S and empty or opened cartridges.
- ▶ For disposal, observe the respective safety data sheets and disposal instructions for the individual components.

ⓘ ⓘ It is not possible to refill empty lubricant cartridges.

## 10. Further notes

### 10.1 Lubricants

Only use lubricants approved by the manufacturer Gruetzner GmbH in the original cartridges developed and manufactured exclusively for the LUB-S.

Further information on the lubricants, documentation and safety data sheets can be obtained directly from the manufacturer Gruetzner GmbH.

### 10.2 Pipe lengths

In principle, it is recommended to mount the LUB-S as close as possible to the consumer (lubrication point). Ideally, this should be done directly at or on the lubrication point. In cases where this is not possible due to the installation space or for reasons of accessibility, pipes can also be used between the LUB-S and the lubrication point (or distributors).

If it is not possible to install the LUB-S directly at the lubrication point, please contact the manufacturer to verify your application.

The influence of temperature, the grease used, the hoses used and the accessories used does not allow any general statement on the possible hose length on the LUB-S.

## 11. Appendix

### 11.1 Dimension sheet and installation dimension

#### LUB-S-V

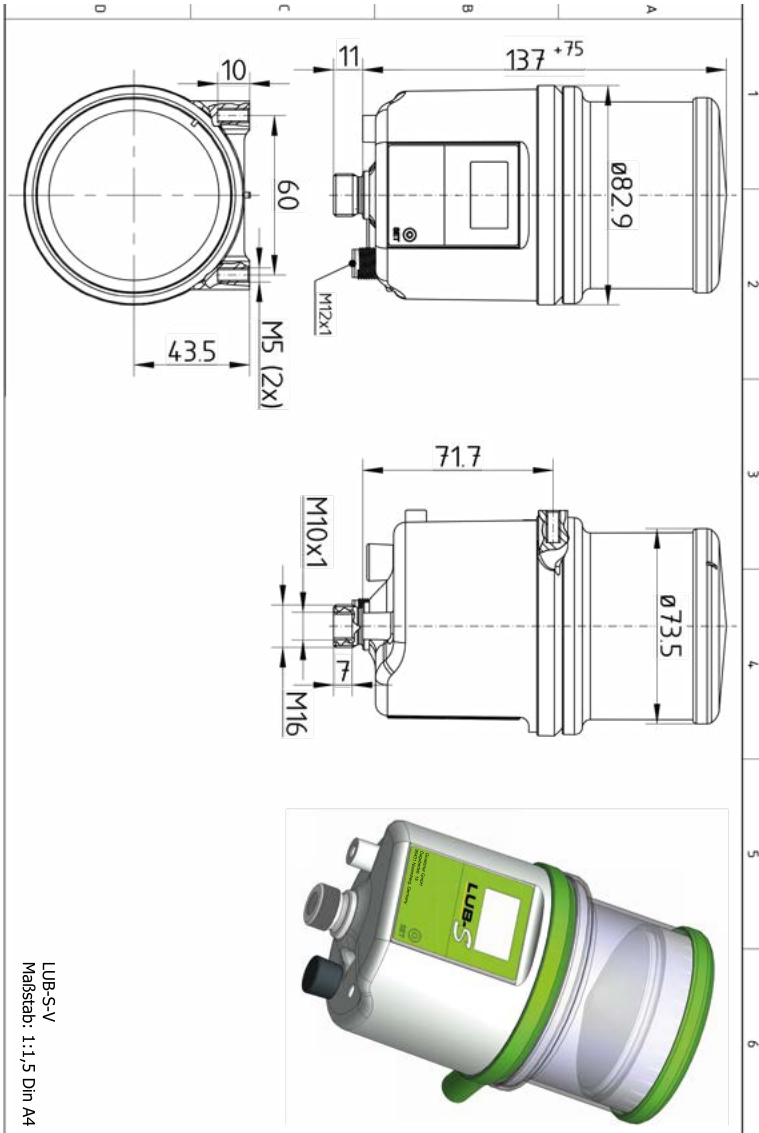

## 11.2 EC/EU Declaration of conformity

### EC declaration of conformity



**Declaration of conformity  
according to EC machinery directive 2006/42/EC as of 17. May 2006**



The manufacturer or authorised representative\*

**Gruetzner GmbH, Dagobertstr. 15, 90431 Nuremberg, Germany**

hereby declares that the following lubrication systems

**Product designation: LUB-S**

**Type designation: LUB-S-V** (24 VDC power supply), **LUB-S-B** (battery powered)

comply with the essential requires of EC directive 2006/42/EC.

The following harmonized standards have been applied:

EN 12100:2011 Safety of machines

Additionally the systems comply with the regulations for electromagnetic compability according to 2004/108/EC.

The following harmonized standards have been applied:

EN 61000-6-2, EN 61000-6-4 electromagnetic compability

Authorised representative for the compilation of technical documents:

Volker Grützner, CEO, Gruetzner GmbH, Dagobertstr. 15, 90431 Nuremberg, Germany

Nuremberg, 01.10.2019



Volker Grützner, CEO

\*must be based within the EU

#### **Gruetzner GmbH**

Dagobertstr. 15

90431 Nuremberg, Germany

Tel: +49 911 277399-0

Fax: +49 911 277399-99

info@G-LUBE.com

www.G-LUBE.com





**GRUETZNER**  
AUTOMATIC LUBRICATION

Gruetzner GmbH is your specialist for automatic lubrication systems since 1993. Our user-friendly lubrication solutions are used in almost all areas of maintenance in every industry across the globe. Flexibility and outstanding service are our core competencies. An individual, custom-built lubrication concept which is adjusted to your machines and constructions will be gladly developed by our experts.

**Gruetzner GmbH**

Dagobertstr. 15 • 90431 Nuremberg, Germany

tel. +49 (0)911 277 399 0 • [info@G-LUBE.com](mailto:info@G-LUBE.com) • [www.G-LUBE.com](http://www.G-LUBE.com)