

4. Mounting

Direct mounting is always preferred.

If the application does not allow direct mounting, remotely assemble the unit using appropriate accessories and keep the distance from the lube point as short as possible (5 metres maximum). For **remote installations** use a 6 mm (inner diameter) tube pre-filled with the same or compatible grease as the grease contained in the unit.

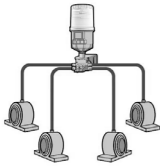

Multiple point installation is possible using a progressive distributor. Do not block any connections to the progressive distributor. Instead use a suitable distributor in accordance with the number of lubrication points. Keep the distance between the distributor and the lubrication unit as short as possible.

NOTE

The Lubricajo LUX B must always be installed in a vertical position. Installing the unit in a non-vertical position may cause damage to the automatic lubricator and your equipment. Incorrect alignment will invalidate the warranty and may lead to safety risks.

5. Start test run



Press the button on the bottom of the LUX base to run a test cycle. Grease will be dispensed during the test cycle.



After dispensing, the LUX base flashes green during normal operation.

For information on other colours, see „6. LED signals“.

6. LED signals

Signals via LED

	<ul style="list-style-type: none"> The test run was activated using the button. The pumping cycle was completed successfully.
	<ul style="list-style-type: none"> Low battery Lubricant cartridge empty.
	<ul style="list-style-type: none"> The gearbox/motor is damaged or defective. The lubrication point or lubrication line may be blocked.

7. Changing the cartridge

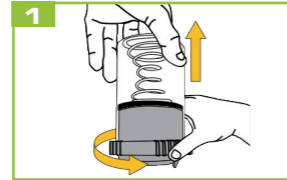

Turn the retaining ring counterclockwise and remove the housing. Remove the empty cartridge. Replace the battery every time you change the cartridge.

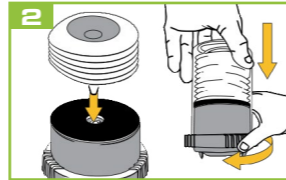

Place the new cartridge in position and place the housing on the drive unit. Secure the housing by turning the retaining ring clockwise on the drive unit.

8. Important information

- The lubricant dispenser is **not** suitable for use with oil.
- Minimize tube resistances. Narrow passages and right angles should be avoided.
- During operation of the device a visual inspection of the device as well as of the lubrication point must be carried out regularly.
- Product warranty is limited to original defects in material and workmanship and does not cover any collateral damage due to mishandling, abuse and/or any other inappropriate use of the device.
- The maximum storage temperature should not exceed +40 °C (+104 °F). Higher temperatures decrease the battery's lifespan. Batteries may be stored for max. 1 year. The lubricator has to be activated within two years from receiving.

LUBRICAJO

LUX B

User manual
LJ-EM-LX-B



1. Product details

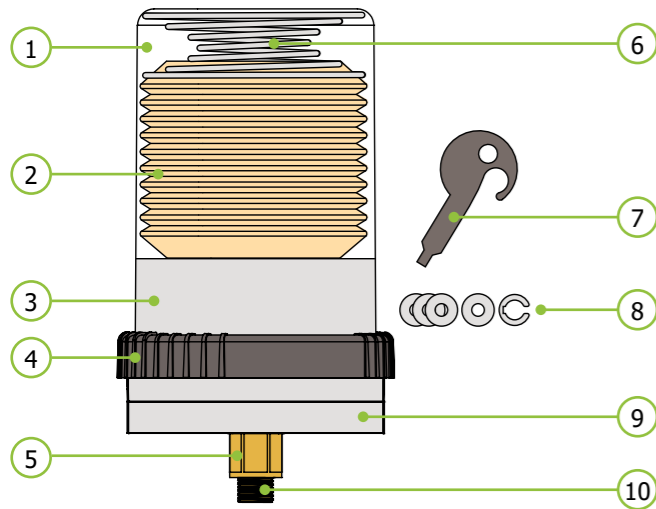

No.	Description	No.	Description
1	Housing	6	Pressure spring
2	Lubricant cartridge	7	Setting key (setting pause time)
3	Drive	8	Stroke washers, circlip (sold separately, Art. no. JAT9052)
4	Retaining ring	9	LUX base with 360° LEDs
5	Outlet	10	Thread male 1/4"

2. Technical data

Housing			
Housing	Al battery	+5 ... +50*	°C
	Li battery	-15 ... +50*	°C
Dimensions (height x Ø)	120 ml: 151 x 101		mm
	240 ml: 182 x 101		
	480 ml: 263 x 101		
Lubricant and hydraulic			
Lubricating medium	greases up to NLGI class 2		
Lubricant volume	120/240/480		ml
Number of lubrication points	up to 12 (with progressive distributors)		
Max. operating pressure	25		bar
Grease delivery	per stroke	0,6 (with stroke washers, reduction down to 0.34 ml possible)	ml
Distribution period	0,25 ... 16 months		
Electrics			
Working voltage (DC)	4,5		V
Protection class	IP64		

* The stated value is down to the individual application and may extensively differ in some cases (depending on the lubricant and further conditions).

3. Installation

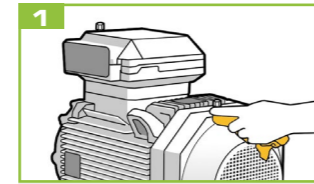

Remove any contaminants around the lube point.

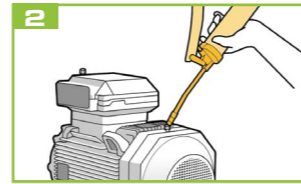

Ensure a clear passage using a manual grease gun.

NOTE The reliable operation depends on completely filled grease lines. Ensure that the grease lines are not blocked. Therefore, grease them before starting the device. Remove any hardened grease by purging the lube point with a manual grease gun.

The grease in the equipment and the grease in the unit should be the same or compatible.



NOTE Remove the grease nipple and install proper connectors.

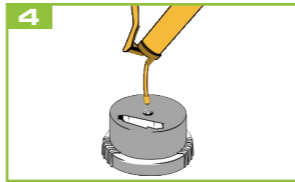
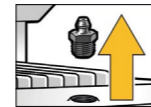

Prime the lubricator using a manual grease gun.

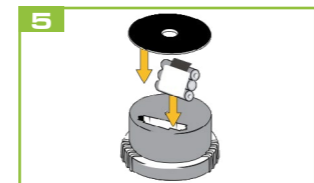

Insert the battery and position the sealing plate.

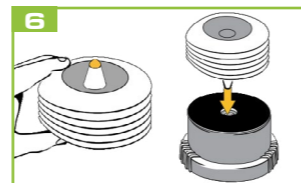

Press the cartridge gently so that some lubricant emerges, then fit it into place.

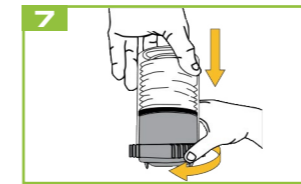

Place the housing on the drive unit. Fasten the housing by turning the retaining ring clockwise on the drive unit.

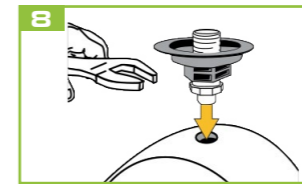

Install the ring adapter at the lubrication point. Please follow the mounting instructions under „4. Mounting“.



Use the key provided to set the desired pause time. Refer to the table opposite to select the value that suits your requirements.

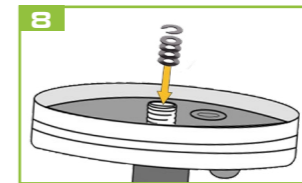

If necessary, then insert the required number of stroke washers and finally the circlip (max. 7 in total).

NOTE Without stroke washers (at full piston stroke), Lubricator LUX B delivers 0.6 ml of lubricant per stroke. Each additional stroke washer in the ring adapter reduces the stroke volume by approximately 0.0375 ml.

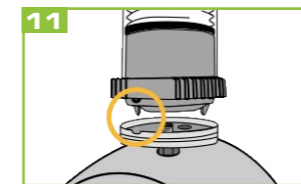

Align the pin on the lubricator with the notch on the LUX base.



Screw the lubricator onto the LUX base in a clockwise direction.

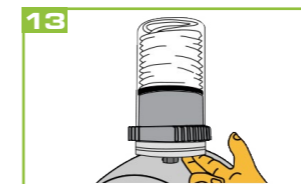

Press the button on the bottom of the LUX base for 5 seconds to start the device.

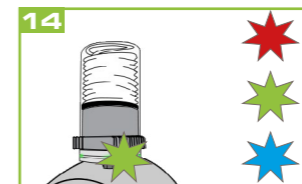

Activation is confirmed by each colour flashing once.

Dial position	Pause time	Dispensing time for 120 ml	Dispensing time for 240 ml	Dispensing time for 480 ml	max. dispensing time	Stroke washers O and circlip C : Setting the quantity of lubricant (reducing the quantity of lubricant increases the dispensing time)															
						0	1	2	3	4	5	6	7	8	9						
						0.28 ml/day	0.26 ml/day	0.24 ml/day	0.22 ml/day	0.2 ml/day	0.18 ml/day	0.17 ml/day	0.3 ml/day	0.6 ml/day	0.9 ml/day	1.2 ml/day	1.8 ml/day	2.4 ml/day	3.6 ml/day	7.2 ml/day	14.4 ml/day
						0.56 ml/day	0.52 ml/day	0.49 ml/day	0.45 ml/day	0.41 ml/day	0.37 ml/day	0.34 ml/day	0.6 ml/day	1.2 ml/day	1.8 ml/day	2.4 ml/day	3.6 ml/day	4.8 ml/day	7.2 ml/day	14.4 ml/day	28.8 ml/day
						0.84 ml/day	0.79 ml/day	0.73 ml/day	0.67 ml/day	0.62 ml/day	0.55 ml/day	0.5 ml/day	0.6 ml/day	1.2 ml/day	1.8 ml/day	2.4 ml/day	3.6 ml/day	4.8 ml/day	7.2 ml/day	14.4 ml/day	28.8 ml/day
						1.12 ml/day	1.04 ml/day	0.98 ml/day	0.9 ml/day	0.82 ml/day	0.74 ml/day	0.68 ml/day	0.6 ml/day	1.2 ml/day	1.8 ml/day	2.4 ml/day	3.6 ml/day	4.8 ml/day	7.2 ml/day	14.4 ml/day	28.8 ml/day
						1.4 ml/day	1.28 ml/day	1.2 ml/day	1.1 ml/day	1 ml/day	0.9 ml/day	0.8 ml/day	0.7 ml/day	1.4 ml/day	2.1 ml/day	2.8 ml/day	3.6 ml/day	4.8 ml/day	7.2 ml/day	14.4 ml/day	28.8 ml/day
						1.7 ml/day	1.62 ml/day	1.46 ml/day	1.35 ml/day	1.23 ml/day	1.1 ml/day	1 ml/day	0.9 ml/day	1.7 ml/day	2.6 ml/day	3.4 ml/day	4.5 ml/day	6 ml/day	8 ml/day	10.8 ml/day	14.4 ml/day
						2 ml/day	1.9 ml/day	1.74 ml/day	1.6 ml/day	1.47 ml/day	1.3 ml/day	1.2 ml/day	1.1 ml/day	2 ml/day	3 ml/day	4 ml/day	5.4 ml/day	7.2 ml/day	9.6 ml/day	12.8 ml/day	17.6 ml/day
						2.4 ml/day	2.2 ml/day	2.04 ml/day	1.8 ml/day	1.65 ml/day	1.5 ml/day	1.4 ml/day	1.3 ml/day	2.4 ml/day	3.6 ml/day	4.8 ml/day	6.4 ml/day	8.4 ml/day	11.2 ml/day	15 ml/day	20 ml/day
						2.8 ml/day	2.6 ml/day	2.4 ml/day	2.2 ml/day	2 ml/day	1.8 ml/day	1.7 ml/day	1.6 ml/day	2.8 ml/day	4.2 ml/day	5.6 ml/day	7.2 ml/day	9.6 ml/day	12.8 ml/day	17.6 ml/day	23.6 ml/day
						3.2 ml/day	3 ml/day	2.8 ml/day	2.6 ml/day	2.4 ml/day	2.2 ml/day	2.1 ml/day	2 ml/day	3.2 ml/day	4.8 ml/day	6.4 ml/day	8.4 ml/day	11.2 ml/day	15 ml/day	20 ml/day	26 ml/day
						3.6 ml/day	3.4 ml/day	3.2 ml/day	3 ml/day	2.8 ml/day	2.6 ml/day	2.5 ml/day	2.4 ml/day	3.6 ml/day	5.4 ml/day	7.2 ml/day	9.6 ml/day	12.8 ml/day	17.6 ml/day	23.6 ml/day	31.6 ml/day
						4 ml/day	3.8 ml/day	3.6 ml/day	3.4 ml/day	3.2 ml/day	3 ml/day	2.9 ml/day	2.8 ml/day	4 ml/day	6 ml/day	8 ml/day	10.8 ml/day	14.4 ml/day	19.2 ml/day	25.6 ml/day	34.4 ml/day
						4.4 ml/day	4.2 ml/day	4 ml/day	3.8 ml/day	3.6 ml/day	3.4 ml/day	3.3 ml/day	3.2 ml/day	4.4 ml/day	6.6 ml/day	8.8 ml/day	11.6 ml/day	15.2 ml/day	20 ml/day	26.4 ml/day	35.2 ml/day
						4.8 ml/day	4.6 ml/day	4.4 ml/day	4.2 ml/day	4 ml/day	3.8 ml/day	3.7 ml/day	3.6 ml/day	4.8 ml/day	7.2 ml/day	9.6 ml/day	12.8 ml/day	17.6 ml/day	23.6 ml/day	31.6 ml/day	41.6 ml/day
						5.2 ml/day	5 ml/day	4.8 ml/day	4.6 ml/day	4.4 ml/day	4.2 ml/day	4.1 ml/day	4 ml/day	5.2 ml/day	7.8 ml/day	10.4 ml/day	13.6 ml/day	18.4 ml/day	24.4 ml/day	32.4 ml/day	42.4 ml/day
						5.6 ml/day	5.4 ml/day	5.2 ml/day	5 ml/day	4.8 ml/day	4.6 ml/day	4.5 ml/day	4.4 ml/day	5.6 ml/day	8.4 ml/day	11.2 ml/day	14.8 ml/day	19.6 ml/day	26 ml/day	34 ml/day	44 ml/day
						6 ml/day	5.8 ml/day	5.6 ml/day	5.4 ml/day	5.2 ml/day	5 ml/day	4.9 ml/day	4.8 ml/day	6 ml/day	9 ml/day	12 ml/day	16 ml/day	21.6 ml/day	28.8 ml/day	38.4 ml/day	50.4 ml/day
						6.4 ml/day	6.2 ml/day	6 ml/day	5.8 ml/day	5.6 ml/day	5.4 ml/day	5.3 ml/day	5.2 ml/day	6.4 ml/day	9.6 ml/day	12.8 ml/day	17.6 ml/day	23.6 ml/day	31.6 ml/day	41.6 ml/day	54.4 ml/day